



Models:
Cinch Pipe & Termination Cap System







These instructions are replacing VP (for Heatilator) and DV (for Heat-N-Glo) pipe assembly instructions. See the appliance installation instructions for configuration of vent assembly and clearances to pipe.

If you need assistance during installation, contact your local dealer or the Technical Services Dept., Hearth & Home Technologies Inc., phone 1-800-927-6841 or 1-888-427-3973.

If DVP-AD adapters are used off the top of the appliance, the termination height will be raised by 2-3/4 in. overall height.

	CAUTION	
	Sharp Edges <ul style="list-style-type: none">• Wear protective gloves and safety glasses during installation.	

	WARNING	
	Hearth & Home Technologies disclaims any responsibility for, and the warranty will be voided by, the following actions: <ul style="list-style-type: none">• Installation and use of any damaged vent system component.• Modification of the vent system.• Installation other than as instructed by Hearth & Home Technologies.• Installation and/or use of any component part not approved by Hearth & Home Technologies.	
	Any such action may cause a fire hazard.	

	WARNING	
	Do not mix pipe, fittings or joining methods from different manufacturers.	

Note: An arrow (➡) found in the text signifies change in content.

1 Parts and Descriptions

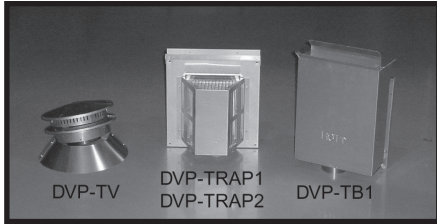

DVP-TV

Vertical termination cap. Includes storm collar and fastener pack.

DVP-TB1

Basement/window well termination cap. Includes fastener pack.

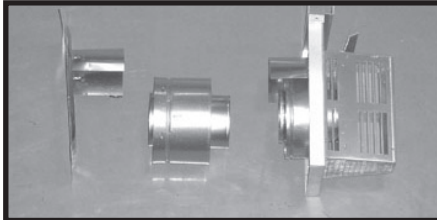

DVP-TRAP1

Horizontal termination cap with 1-3/4 in. telescoping flue. Includes DVP-WS wall shield with heat shield and one fastener pack.

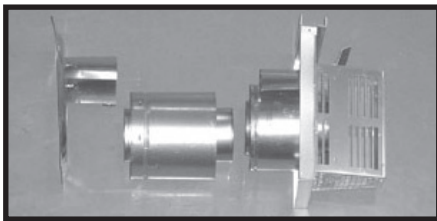

DVP-TRAP2

Horizontal termination cap with 4 in. telescoping flue. Includes DVP-WS wall shield with heat shield and one fastener pack.

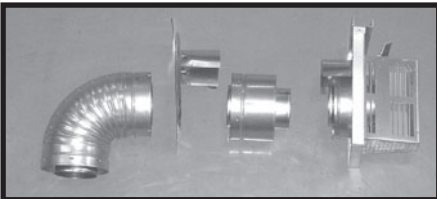

DVP-TRAPK1

Vent kit containing DVP90ST 90° elbow, DVP-WS wall shield with heat shield, DVP-TRAP1 termination cap with telescoping flue and one fastener pack.

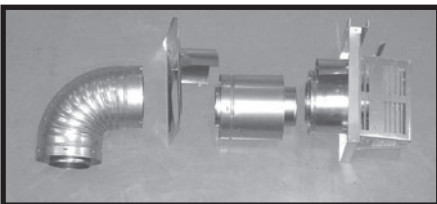

DVP-TRAPK2

Vent kit containing DVP90ST 90° elbow, DVP-WS wall shield with heat shield, DVP-TRAP2 termination cap with telescoping flue and one fastener pack.



DVP-TVHW

Vertical Termination, high wind cap. Includes storm collar and fastener pack.

(not shown)

DVP-AS

Attic insulation shield

BEK

Brick extension kit

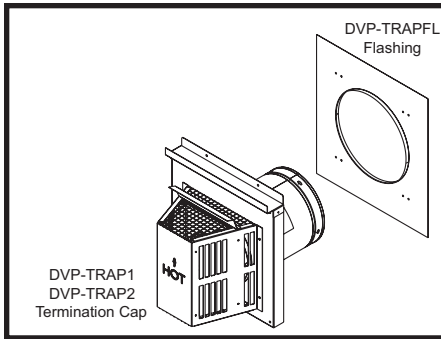

DVP-TRAPFL

DVP-TRAP1 or DVP-TRAP2 termination cap rain flashing

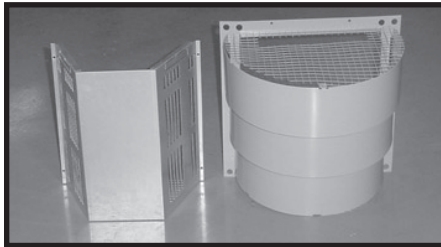

COOL ADD

Cap shield

DRC-RADIUS

Cap shield

Components	Description
DRC-RADIUS	Cap Shield
COOL-ADDM	Cap Shield - pack of six
DVP-TV	Vertical Termination Cap
DVP45	45° Elbow
DVP90ST	90° Elbow
RF6M	Roof Flashing (vertical termination for 0/12 to 6/12 pitch) - pack of four
RF12M	Steep Pitch Roof Flashing (for 7/12 to 12/12 pitch) - pack of six
DVP4	4 in. length Vent Pipe
DVP6	6 in. length Vent Pipe
DVP12	12 in. length Vent Pipe
DVP24	24 in. length Vent Pipe
DVP36	36 in. length Vent Pipe
DVP48	48 in. length Vent Pipe
DVP6A	3 in. - 6 in. Slip Section Vent Pipe (to be used with another piece of pipe)
DVP12A	3 in. - 12 in. Slip Section Vent Pipe (to be used with another piece of pipe)
DVP12MI	12 in. Vent Pipe - non-unitized (can be cut to length)
DVP24MI	24 in. Vent Pipe - non-unitized (can be cut to length)
DVP-HVS	Vent Support
DVP-WS	Wall Shield to ensure horizontal clearances
DVP-FS	Firestop Spacer
DVP-TRAP1	Horizontal Termination Cap with 1-3/4 in. telescoping flue and wall shield with heat shield
DVP-TRAP2	Horizontal Termination Cap with 4 in. telescoping flue and wall shield with heat shield
DVP-TB1	Basement Horizontal Termination Cap
DVP-TRAPK1	Top Vent Horizontal Kit with DVP-TRAP1 Termination Cap, wall shield with heat shield, and 90° elbow
DVP-TRAPK2	Top Vent Horizontal Kit with DVP-TRAP2 Termination Cap, wall shield with heat shield, and 90° elbow
DVP-HSM	Extended Heat Shield
BEK	Brick Extension Kit
DVP-AS	Attic Insulation Shield

Vent depth is measured from the back of the appliance to the outer edge of the exterior wall. See Table 1 and Figure 1.

TRAP CAP SPECIFICATION CHART

Appliance	DVP-TRAPK1 Top Vent Depth	DVP-TRAP1 Rear Vent Depth	DVP-TRAPK2 Top Vent Depth	DVP-TRAP2 Rear Vent Depth
Novus	4-1/2 in. to 6-1/4 in.	3-1/2 in. to 4-3/4 in.	7 in. to 11 in.	5-1/2 in. to 9-1/2 in.
NXT	4-1/8 in. to 5-7/8 in.	4-5/8 in. to 6-3/8 in.	6-1/2 in. to 10-1/2 in.	7-1/4 in. to 11-1/4 in.
Caliber	4-1/8 in. to 5-7/8 in.	3-5/8 in. to 5-3/8 in.	6-1/2 in. to 10-1/2 in.	6-1/4 in. to 10-1/4 in.
Maxus	4-1/2 in. to 6-1/4 in.	4-1/8 in. to 5-7/8 in.	6-7/8 in. to 10-7/8 in.	6-3/4 in. to 10-3/4 in.
GNTC50	5 in. to 6-3/4 in.	4-7/8 in. to 6-5/8 in.	7-3/8 in. to 11-3/8 in.	7-3/8 in. to 11-3/8 in.
Designer*	4 in. to 5-3/4 in.	5-3/4 in. to 7-1/2 in.	6-3/8 in. to 10-3/8 in.	8-1/8 in. to 12-1/8 in.
Titan	3-1/2 in. to 5-1/4 in.	N/A	6 in. to 10 in.	N/A
6000	2-3/4 in. to 4-1/2 in.	3-1/8 in. to 4-7/8 in.	5-1/4 in. to 9-1/4 in.	5-5/8 in. to 9-5/8 in.
8000	2-3/4 in. to 4-1/2 in.	3-1/8 in. to 4-7/8 in.	5-1/4 in. to 9-1/4 in.	5-5/8 in. to 9-5/8 in.
Olympian	3-1/2 in. to 5-1/4 in.	N/A	6 in. to 10 in.	N/A
Multisided	7-1/2 in. to 9-1/4 in.	3-1/8 in. to 4-7/8 in.	10 in. to 14 in.	5-5/8 in. to 9-5/8 in.
Gem	4-1/2 in. to 6-1/4 in.	N/A	7 in. to 11 in.	N/A
SL units	N/A	3-1/8 in. to 4-7/8 in.	N/A	5-5/8 in. to 9-5/8 in.
ICON	3-1/2 in. to 5-1/4 in.	N/A	6-1/2 in. to 10-1/2 in.	N/A
GDST5244I**	4 in. to 5-3/4 in.	N/A	6-3/4 in. to 7-3/4 in.	N/A

* Top vented appliance - Designer needs a DVP12 after the elbow.

** GDST5244I requires a DVP12 and DVP6 after the elbow.

Table 1

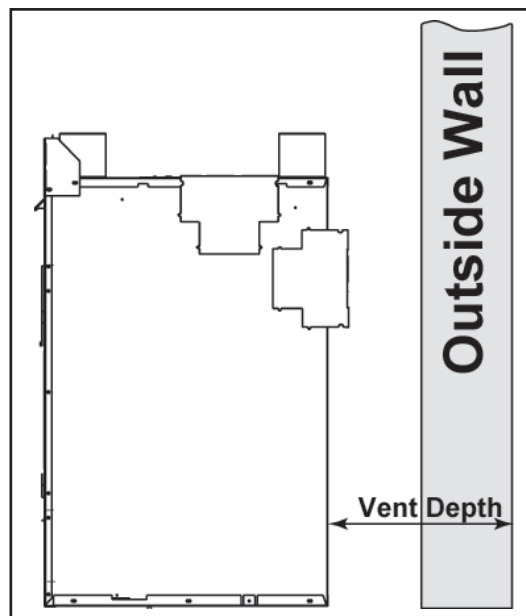

Figure 1 - Measuring Required Vent Depth

2 Installing Vent Pipe

Note: For termination cap installations only, go directly to Section E.

A. Clearances for the Vent Sections

• Top Vented Direct Vent Appliances

For all top vented, direct vent appliances, clearances to combustible materials from the venting system need to be maintained as shown in Figure 2.1.

• Rear Vented Direct Vent Appliances

See Figure 2.2.

Note: Refer to the appliance installation instructions for allowed vent lengths and configurations.

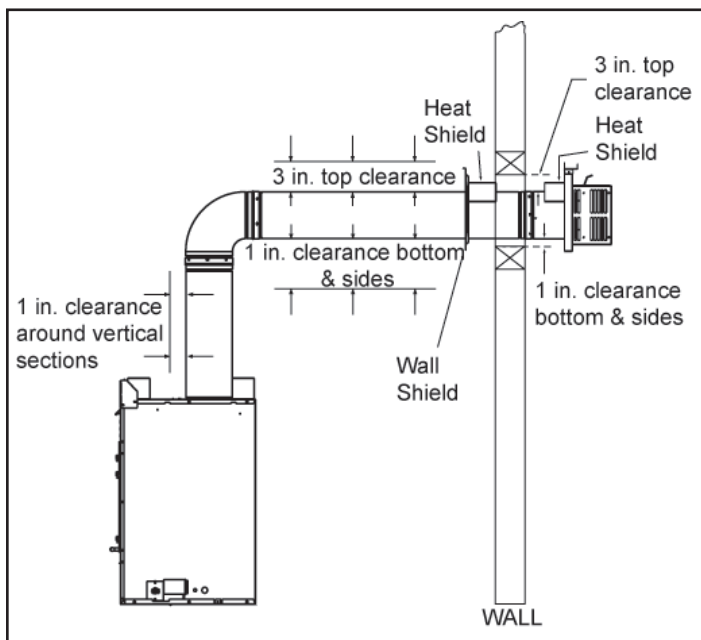

Figure 2.1 Horizontal Venting Clearances to Combustible Materials - Top Vent

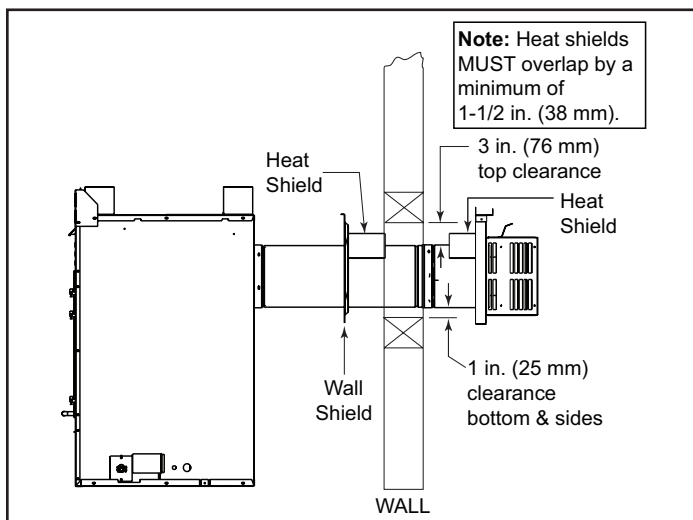

Figure 2.2 Horizontal Venting Clearances to Combustible Materials - Rear Vent

Note: Heat shields MUST overlap by 1-1/2 in. min. for rear vented appliances.

B. Penetrating a Wall

Wherever a combustible wall is penetrated, the hole must be framed with an interior wall shield (DVP-WS) as shown in Figures 2.3-2.4. This shield maintains minimum clearances and restricts cold air infiltration. If the wall being penetrated is of noncombustible materials (material which will not ignite or burn, or has a UL fire rating of zero), a 9 in. diameter hole is acceptable. Whenever a wall is penetrated the wall shield is only required on one side and no heat shield is necessary. If your local inspector requires the wall shield on both sides, then both wall shields must have a heat shield attached to them.

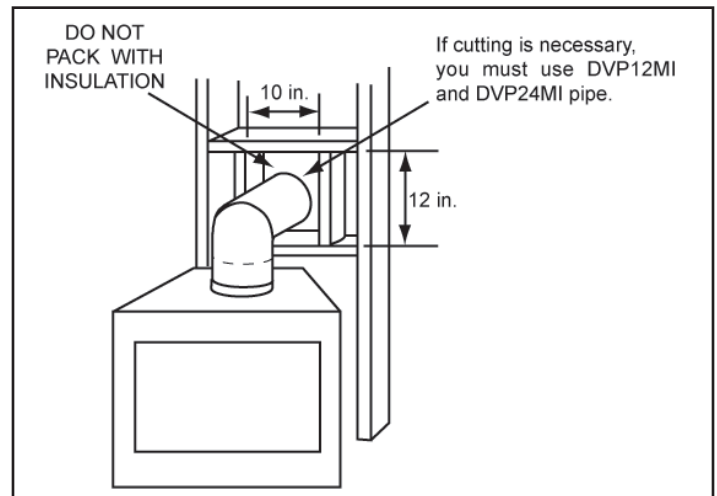

Figure 2.3 Exterior Wall Hole

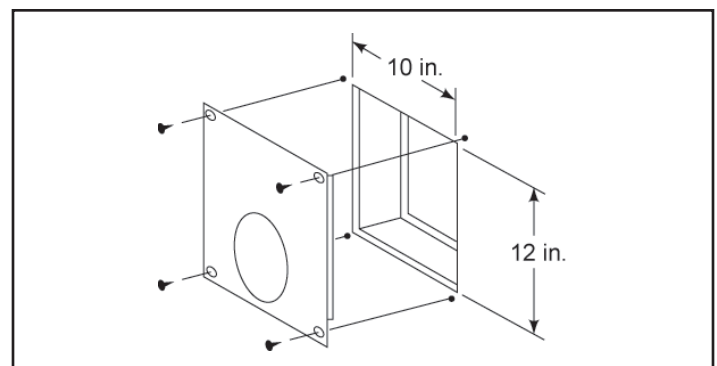

Figure 2.4 Interior Wall Shield



⚠ WARNING

Fire Risk

Explosion Risk



Maintain vent clearance to combustibles as specified.

- Do not pack air space with insulation or other materials.

Failure to keep insulation or other materials away from vent pipe may cause fire.



C. Assemble Vent Sections

	WARNING
	Fire Risk Exhaust Fumes Risk
	<ul style="list-style-type: none">• Overlap pipe slip sections at least 1-1/2 inches.• Use pilot holes for screws.• Screws must not exceed one inch long.• Pipe may separate if not properly joined.

Attaching Vent to the Firebox Assembly

To attach the first pipe section to the collars, slide the male end of the inner vent of the pipe section over the inner collar on the firebox assembly. At the same time, slide the outer flue over the outer collar on the appliance. Push the pipe section into the appliance collar until all the lances (see Figure 2.5) have snapped in place. Tug slightly on the section to confirm it has completely locked into place.

Assemble Pipe Sections

Insert the inner flue of section A into the flared inner flue of section B.

Start the outer flue of section A over the outer flue of section B (see Figure 2.6).

Note: The end of the pipe sections with the lances/tabs on it will face towards the appliance.

Once both inner and outer flues are started, press section A onto section B firmly until all lances have snapped into place. Check to make sure they have snapped together (see Figure 2.7) and the seams are not aligned (see Figure 2.8). Tug slightly on section A to confirm it has completely locked into place.

For 90° and 45° elbows that are changing the vent direction from horizontal to vertical, one screw minimum should be put in the outer flue at the horizontal elbow joint to prevent the elbow from rotating.

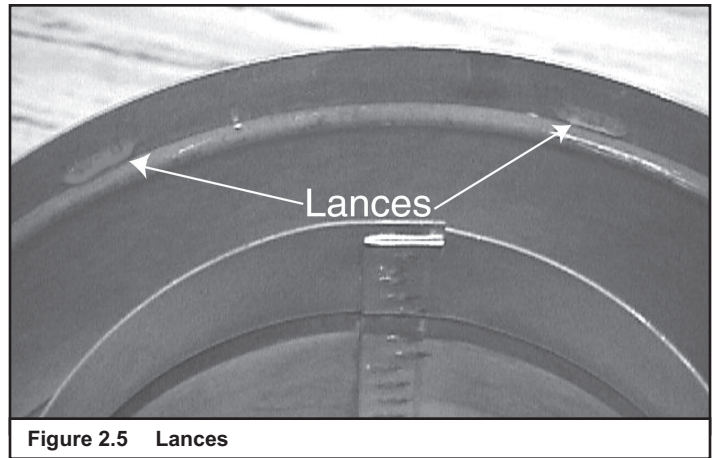

Figure 2.5 Lances

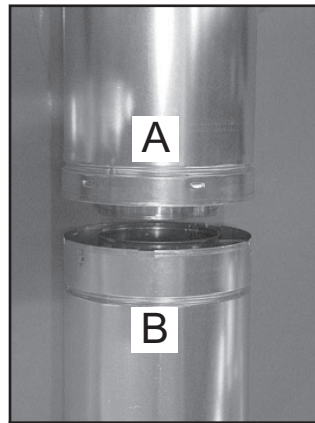

Figure 2.6 Inner/Outer

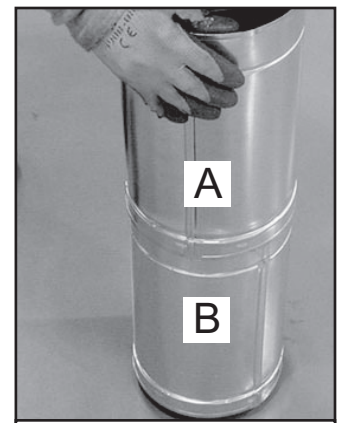

Figure 2.7 Snapped

Make sure the seams are not aligned to prevent unintentional disconnection.

	
CORRECT	INCORRECT

Figure 2.8 Seams

Assemble Minimum Installation (MI) Sections

MI sections are non-unitized so that they can be cut to a specific length. Cut these sections to length from the non-expanded end (see Figure 2.9).

They can then be attached by first connecting the expanded end of the MI inner flue with the inner pipe from the adjacent pipe section and securing with three screws. The expanded portion of the MI inner flue must overlap completely with the unexpanded end of the adjacent pipe section.

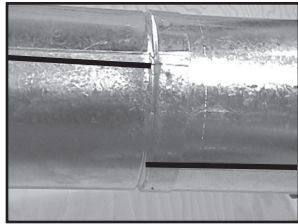
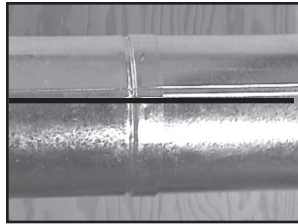
The outer flue can then be inserted into the adjacent outer flue expanded end and attached to the next pipe section with three screws. The other end of the MI pipe section can then be attached by fitting another pipe section to it and snapping it together, as normal.

Assemble Slip Sections

The outer flue of the slip section should slide over the outer flue of the pipe section and into (inner flue) the last pipe section (see Figure 2.10).

Slide together to the desired length, making sure that a 1-1/2 in. outer flue overlap is maintained between the pipe section and slip section.

The pipe and slip section need to be secured by driving two screws through the overlapping portions of the outer flues using the pilot holes (see Figure 2.11).

This will secure the slip section to the desired length and prevent it from separating. The slip section can then be attached to the next pipe section.

If the slip section is too long, the inner and outer flues of the slip section can be cut to the desired length.

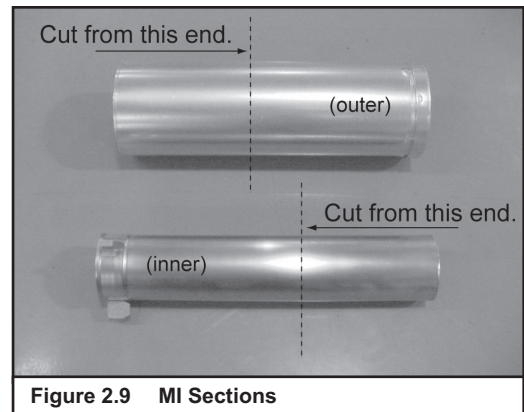

Figure 2.9 MI Sections

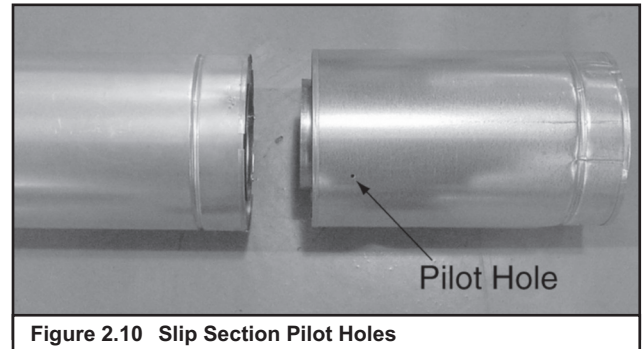

Figure 2.10 Slip Section Pilot Holes

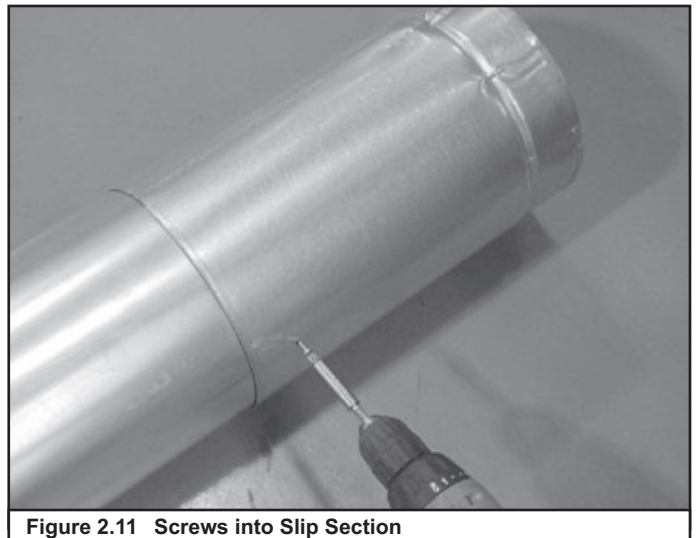

Figure 2.11 Screws into Slip Section

Secure the Vent Sections

Vertical sections of pipe must be supported every 8 ft after the 25 ft maximum unsupported rise. The vent support or plumber's strap (spaced 120° apart) may be used to do this (see Figures 2.12 and 2.13).

Horizontal sections of vent must be supported every 5 ft with a vent support or plumber's strap.

D. Disassemble Vent Sections

To disassemble any two pieces of pipe, rotate either section (see Figure 2.14), so that the seams on both pipe sections are aligned (see Figure 2.15). They can then be carefully pulled apart.

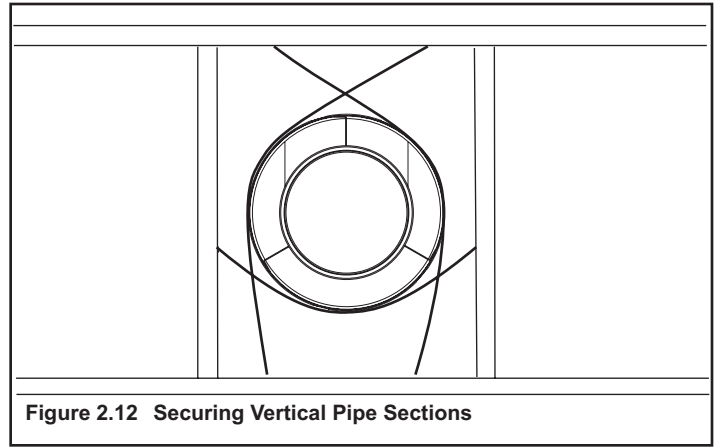

Figure 2.12 Securing Vertical Pipe Sections

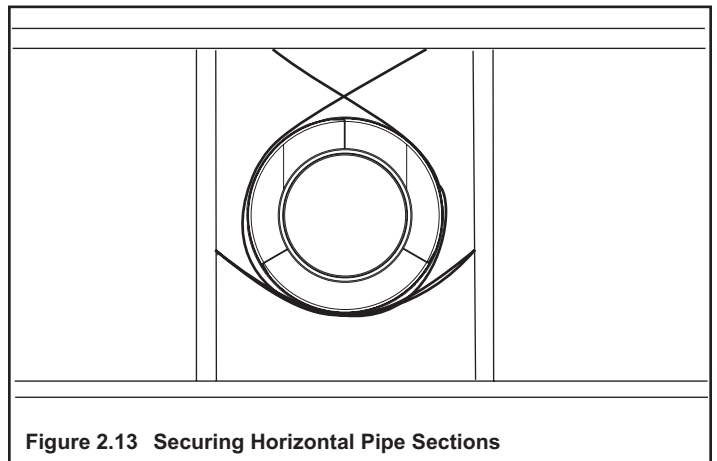





Figure 2.13 Securing Horizontal Pipe Sections

	WARNING
	Fire Risk Explosion Risk Asphyxiation Risk
	Use vent run supports per installation instructions. Connect vent sections per installation instructions
	<ul style="list-style-type: none">• Maintain all clearances to combustibles.• Do NOT allow vent to sag below connection point to appliance.• Maintain specified slope (if required).
	Improper support may allow vent to sag or separate.

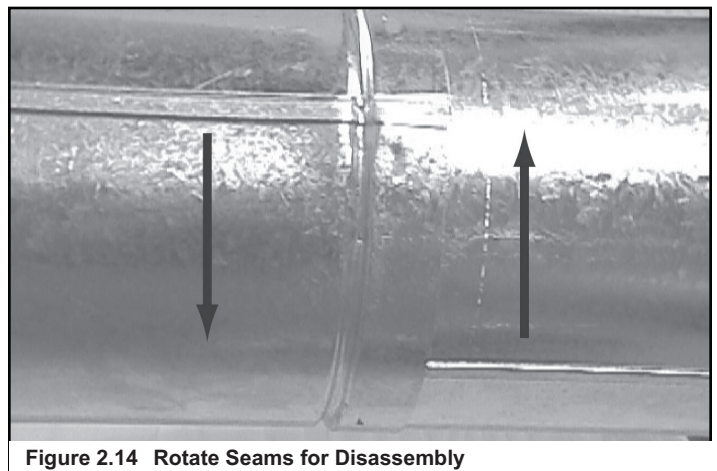

Figure 2.14 Rotate Seams for Disassembly

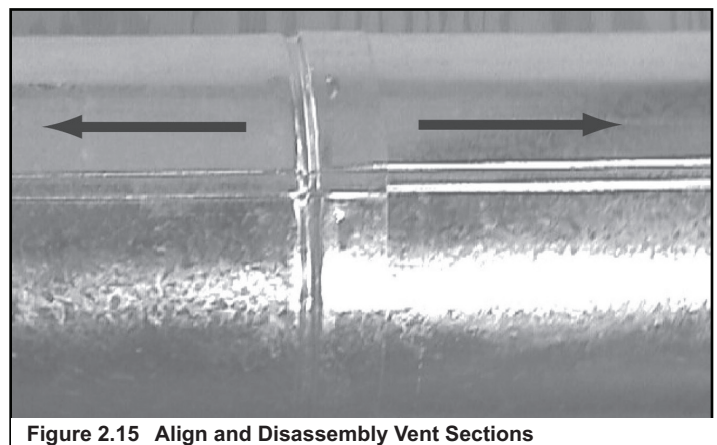

Figure 2.15 Align and Disassembly Vent Sections

E. Install the Heat Shield and Horizontal Termination Cap

WARNING

A 1-1/2 in. minimum overlap **MUST** be maintained on the telescoping flue section of the cap.

on the extended heat shield should rest on the top of the vent (pipe section) to properly space it from the pipe section.

Install the Horizontal Termination Cap

Vent termination must not be recessed in the wall. Siding may be brought to the edge of the cap base.

Caulk the outside edges of the cap.

When installing a horizontal termination cap, follow the cap location guidelines as prescribed by current **ANSI Z223.1** and **CAN/CGA-B149** installation codes.



WARNING

Fire Risk Exhaust Fumes Risk

Impaired performance of appliance.

- Overlap pipe slip sections at least 2 in.
- Use pilot holes for screws.
- Screws must not exceed 1 in. long.
- Pipe may separate if not properly joined.



WARNING



Burn Risk

- Local codes may require installation of a cap shield to prevent anything or anyone from touching the hot cap.

Heat Shield Requirements for Horizontal Termination

For all horizontally vented appliances, a heat shield **MUST** be placed 1 in. above the top of the vent between the wall shield and the base of the termination cap.

There are two sections of the heat shield. One section attaches to the wall shield with two screws. The remaining section is attached to the cap in the same manner. See Figure 2.16.

If the wall thickness does not allow the required 1-1/2 in. heat shield overlap, an extended heat shield must be used.

The extended heat shield will need to be cut to the thickness of the wall and be attached to the wall shield. The small leg

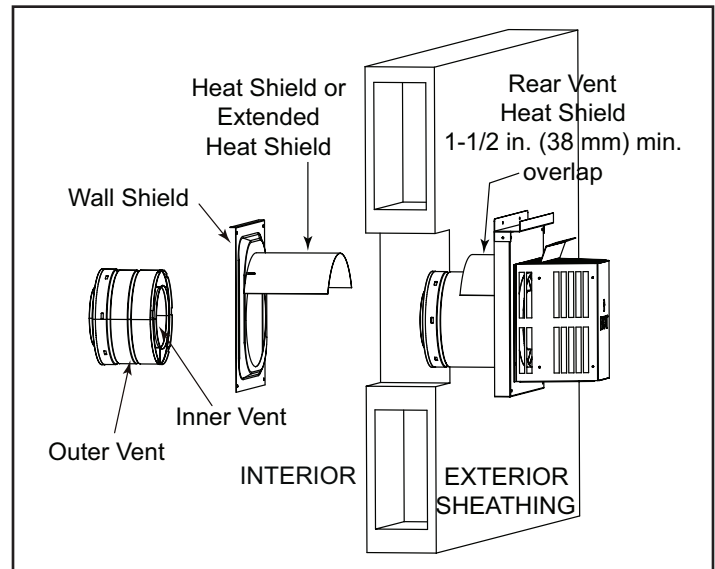

Figure 2.16 Venting through the Wall

WARNING

Do **NOT** connect a pipe section to a termination cap without using the telescoping flue section found on the termination cap.

Note: Where required, an exterior wall flashing is available. When penetrating a brick wall, a brick extension kit is available for framing the brick.

F. Vertical Penetration Framing



⚠ WARNING

Fire Risk

Keep loose materials or blown insulation from touching the vent pipe.

- National building codes recommend using attic shield to keep loose materials/blown insulation from contacting vent.
- Hearth & Home Technologies requires the use of an attic shield.

Install the Firestop Spacer

- Frame an opening 10 in. by 10 in. whenever the vent system penetrates a ceiling/floor (see Figure 2.17).
- Frame the area with the same sized lumber as used in ceiling/floor joist.
- When installing a top vent vertical appliance the hole should be directly above the appliance, unless the flue is offset.
- Do not pack insulation around the vent. Insulation must be kept away from the pipe.

Note: The firestop spacer is not required if attic insulation shield is used.

Install Attic Insulation Shield

- Frame opening for attic insulation shield.
- Attic insulation shield may be installed above or below ceiling (see Figure 2.18).
- Secure with three fasteners on each side.
- Fold tabs at top of attic shield in toward vent pipe. Tabs must keep vent pipe centered within shield.
- Field construct additional shield height if insulation is deeper than height of attic shield.

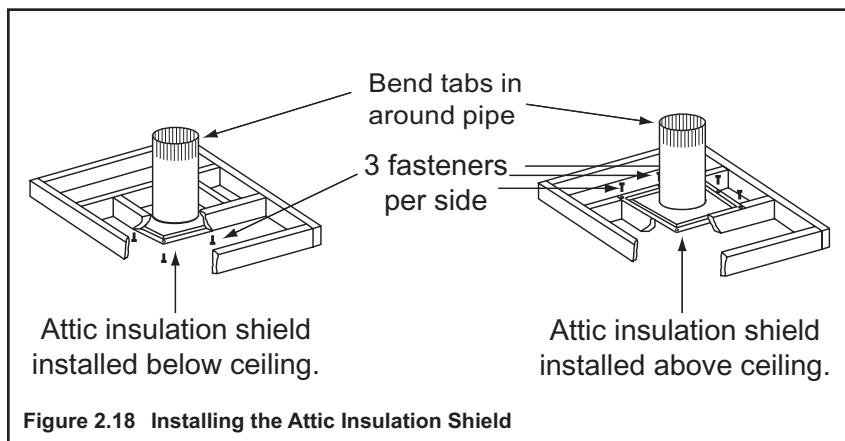
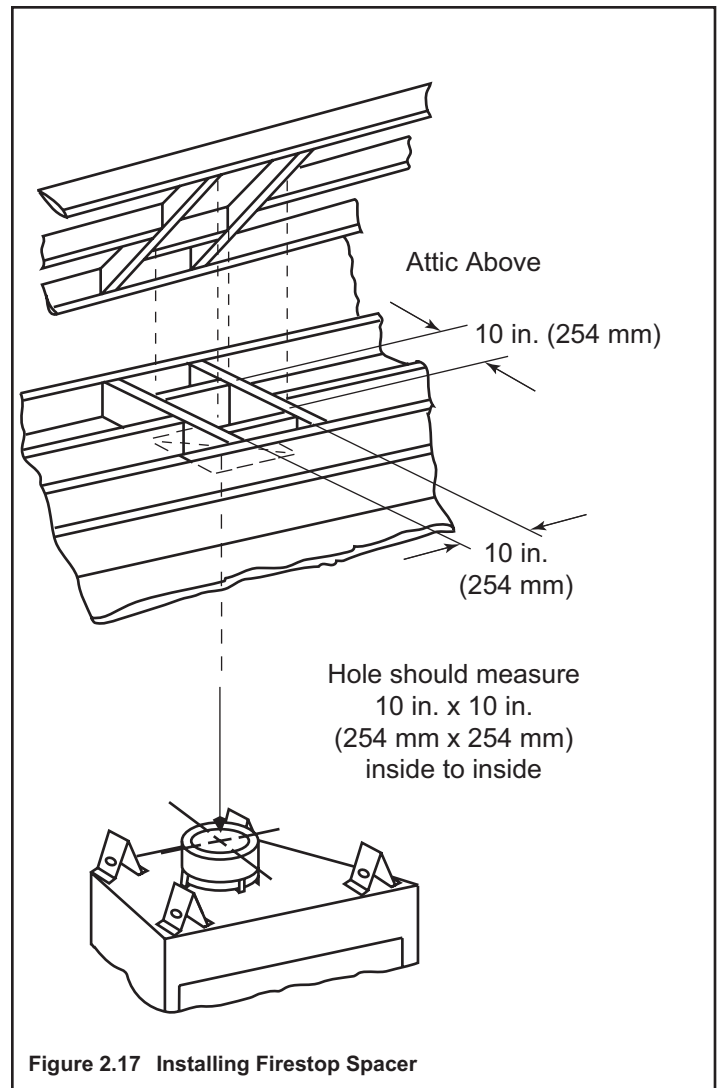

G. Install Roof Flashing and Vertical Termination Cap

To install roof flashing see Figure 2.19.

For installation of vertical termination cap see minimum vent heights for various pitched roofs (Figure 2.19) .

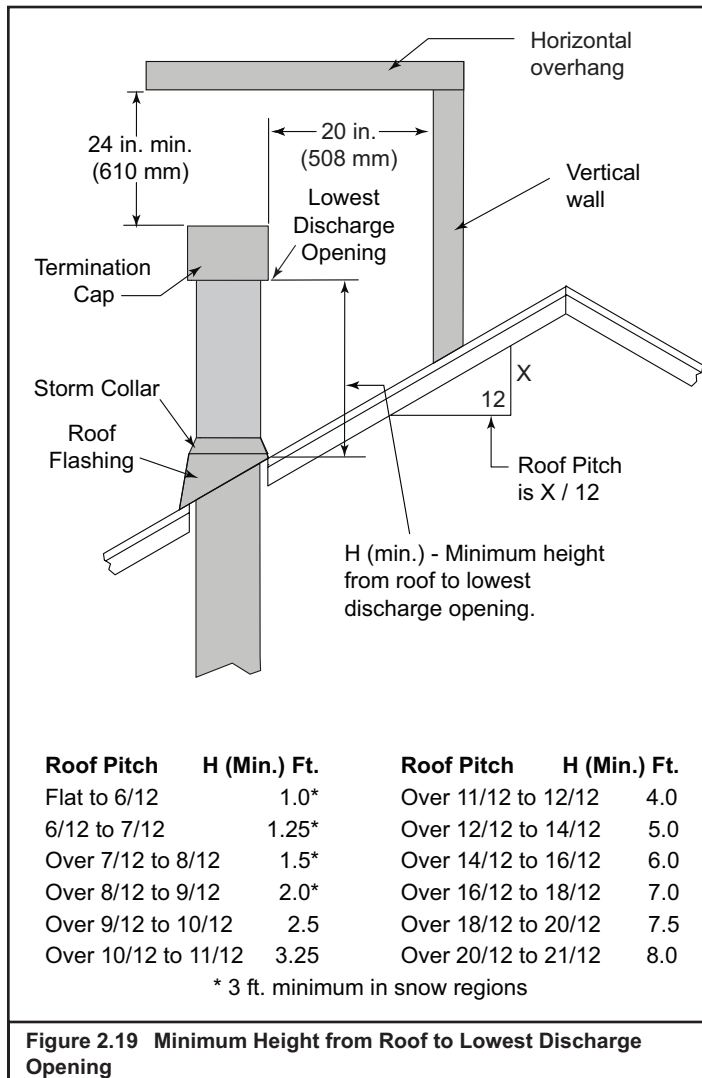

To attach the vertical termination cap, slide the inner collar of the cap into the inner flue of the pipe section and place the outer collar of the cap over the outer flue of the pipe section.

Secure with three screws into the outer flue. Secure the cap by driving the three self-tapping screws (supplied) through the pilot holes in the outer collar of the cap into the outer flue of the pipe (see Figure 2.20).

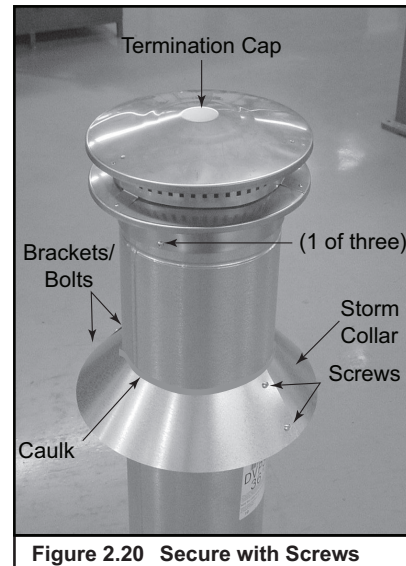

WARNING



Fire Risk

Explosion Risk

Inspect external vent cap regularly.

- Ensure no debris blocks cap.
- Combustible materials blocking cap may ignite.
- Restricted air flow affects burner operation.

H. Assemble and Install Storm Collar

	CAUTION	
	Sharp Edges! <ul style="list-style-type: none">• Wear protective gloves and safety glasses during installation.	

Connect both halves of the storm collar with two screws (see Figure 2.21).

Wrap the storm collar around the exposed pipe section and align brackets. Insert a bolt (provided) through the brackets and tighten nut to complete the storm collar assembly (see Figure 2.22). Make sure the collar is tight against the pipe section.

Slide the assembled storm collar down the pipe section until it rests on the roof flashing (see Figure 2.19).

Caulk around the top of the storm collar.

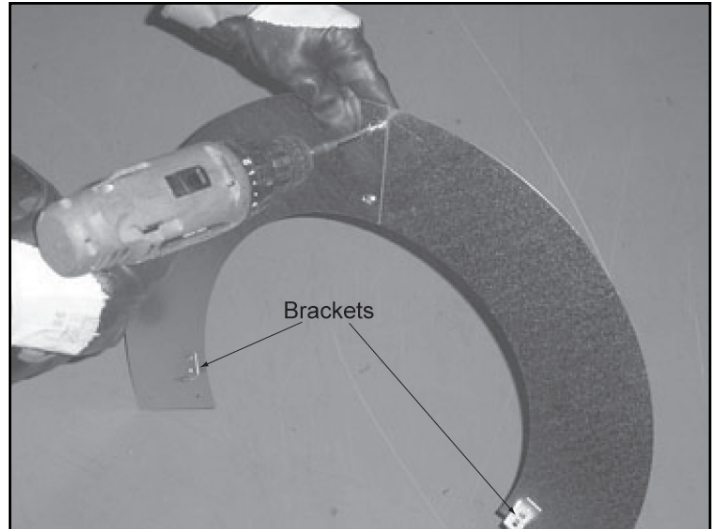

Figure 2.21 Assembling the Storm Collar



Figure 2.22 Assembling the Storm Collar Around the Pipe