



BROILMASTER® PREMIUM GAS GRILLS

Premium "P" Gas Grill Owner's Manual

MODELS:

P3S-1, P3SN-1

P3BL-2, P3BLW-2, P3BLN-2, P3BLWN-2

P3FBL-2, P3FBLN-2, P3FBLW-2, P3FBLWN-2

P4BL-1, P4BLN-1, P4BLW-2, P4BLWN-2

P4FBL-1, P4FBLN-1, P4FBLW-2, P4FBLWN-2

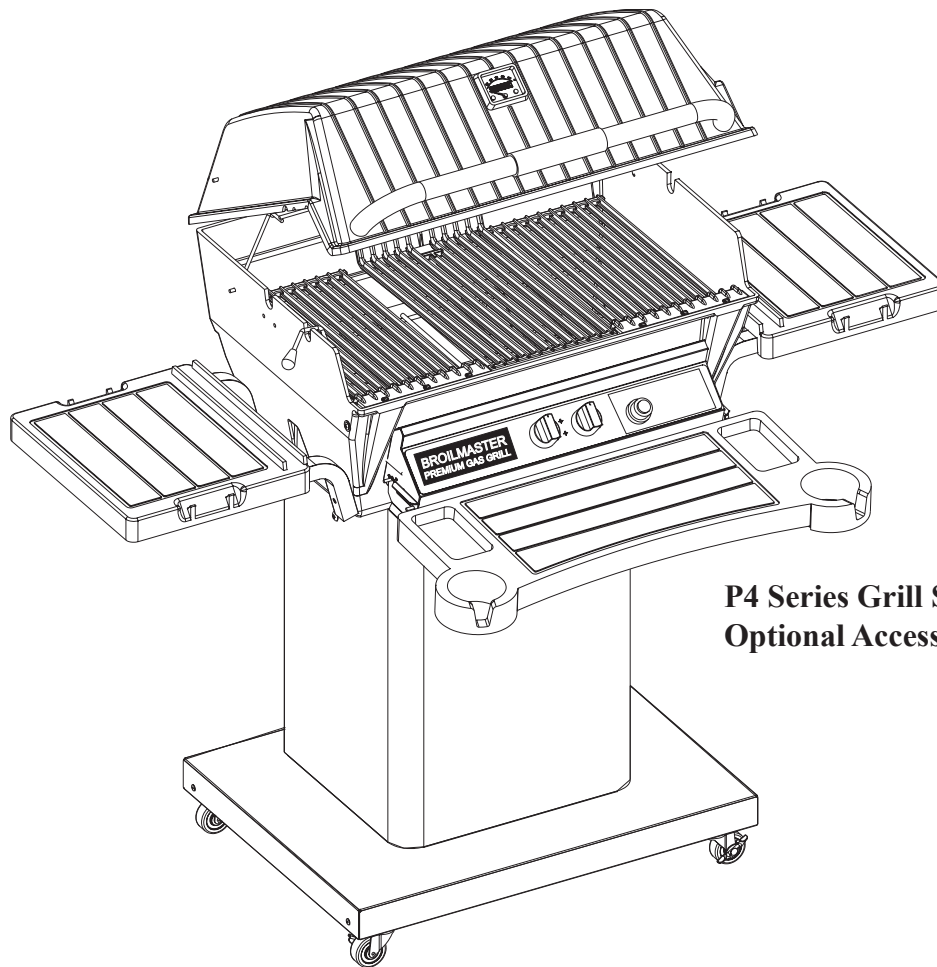

**P4 Series Grill Shown With
Optional Accessories**

GAS-FIRED



IMPORTANT

This manual should be read thoroughly by the person installing the grill and all persons who will use and maintain the grill. The installer should be sure the manual is left in the possession of the user. The user should retain this manual for future reference when using or cleaning the grill and to properly identify any repair parts that may be required.

WARNING

Reference this manual for proper installation and maintenance instructions. Improper installation, adjustment, alteration, service or maintenance can cause personal injury or property damage. For assistance or additional information consult a qualified installer, service agency or the gas supplier.

CAUTION: FOR YOUR SAFETY

IF YOU SMELL GAS:

1. Shut off gas to the appliance.
2. Extinguish any open flame.
3. Open the grill lid.
4. If odor continues, immediately call your gas supplier or fire department.
5. Do not touch electrical switches.

CAUTION: FOR YOUR SAFETY

1. Do not store or use gasoline or other flammable vapors and liquids in the vicinity of this or any other appliance.
2. An LP cylinder not connected for use shall not be stored in the vicinity of this or any other appliance.

CAUTION:

Parts may have sharp edges. Wear leather work gloves and handle parts carefully during the unpacking, assembly and installation.

WARNING

Broilmaster® Gas Grills must ONLY use propane cylinders equipped with an Overfill Protection Device (OPD). Use only a reputable propane dealer when exchanging or filling cylinders. An overfilled or improperly filled propane cylinder can be dangerous.

TABLE OF CONTENTS

Congratulations!

You have chosen the finest grill for your outdoor cooking pleasure. Please take time to read this entire manual before assembling your Premium Broilmaster® gas grill.

Hardware Package	5
Parts Diagram	6
Parts List	7 & 8
Grill Assembly	9-13
Propane Gas Grills.....	14-16
Gas Conversion.....	17
Natural Gas Grills.....	18
Operation- Propane & Natural Grills.....	19 & 20
Maintenance	21
Troubleshooting	22
Warranty	23

Your Broilmaster® Premium Gas Grill is identified by model number, serial number, and gas type. This information is provided on a product identification label located on the grill's control panel. For your convenience, complete this section for future reference when contacting your dealer.

Model No. _____ Dealer _____

Serial No. _____ Dealer Phone No. _____

Gas Type: Propane _____ Natural _____ Date of Purchase _____

HARDWARE PACKAGE



B073978 SCREW #10-24 X 1 PHILLIPS TRUSS STAINLESS

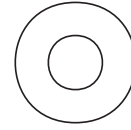

B076332 9/32 ID X 5/8 OD FLAT WASHER SS

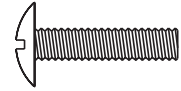

B100128 SCREW #10-24 X 3/4 PHILLIPS TRUSS HEAD BLACK



B073967 #10-24 KEPS NUT STAINLESS

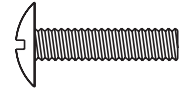

B076522 SCREW #10-24 X 3/4 PHILLIPS TRUSS HEAD STAINLESS



B662325 HANDLE SPACER

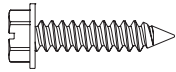

B101022 SCREW #8 X 3/4 Stainless Steel HEX HEAD

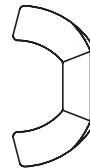

B100125 10-24 WING NUT BOS

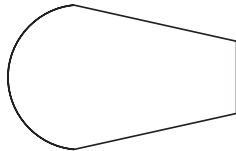
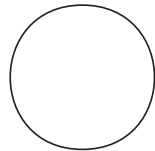

B100098 KNOB

PREMIUM "P" SERIES PARTS LIST

Index	Part Description	Part Number							
		P3BL & P3BLN	P3HG & P3HGN	P3GY & P3GYN	P3FBL & P3FBLN	P3FGY & P3FGYN	P3S & P3SN	P3BLW & P3BLWN	P3FBLW & P3FBLWN
1	Grill Body Top (with heat indicator, hinge, and bridge pins)	B100453	B100455	B100454	B100453	B100454	B100453	B100453	B100453
1	Grill Body Top (casting only)	B100456	B100459	B100458	B100456	B100458	B100456	B100456	B100456
2	Heat Indicator (stainless)	B076625	B076625	B076625	B076625	B076625	B076625	B076625	B076625
3	Lid Handle (stainless)	B070486	B070486	B070486	B070486	B070486	B070486	B070486	B070486
4	Foam Grip	B073097	B073097	B073097	B073097	B073097	B073097	B073097	B073097
5	Retract-A-Rack (stainless)	B072695	B072695	B072695	B072695	B072695	B072695	B072695	B072695
6A	Cooking Grid (2 piece Porcelain)	B101053	B101053	B101053	B101053	B101053	N/A	N/A	N/A
6B	Cooking Grid (3 piece Porcelain)	N/A	N/A	N/A	N/A	N/A	B100589	N/A	N/A
6C	Cooking Grid (2 piece Stainless Steel Rod)	N/A	N/A	N/A	N/A	N/A	N/A	B101282	B101282
7	Briquette Bag	B058122	B058122	B058122	N/A	N/A	N/A	B058122	N/A
8	Briquette Rack	B101061	B101061	B101061	N/A	N/A	N/A	B101061	N/A
9	Burner Assembly	DPP101	DPP101	DPP101	DPP101	DPP101	DPP101	DPP101	DPP101
10	Radiation Shield (Heat & Wind Deflector)	DPP6SS	DPP6SS	DPP6SS	DPP6SS	DPP6SS	DPP6SS	DPP6SS	DPP6SS
11	Bridge Pin	B057805	B057805	B057805	B057805	B057805	B057805	B057805	B057805
12	Hinge Pin	B057804	B057804	B057804	B057804	B057804	B057804	B057804	B057804
13	Lid Stop Kit	DPA106	DPA106	DPA106	DPA106	DPA106	DPA106	DPA106	DPA106
14	Orifice - LPG (#55 drill)	B056649	B056649	B056649	B056649	B056649	B056649	B056649	B056649
14	Orifice - NAT (#48 drill)	B056647	B056647	B056647	B056647	B056647	B056647	B056647	B056647
15	Manifold Mounting Plate	B100517	B100517	B100517	B100517	B100517	B100517	B100517	B100517
16	Manifold - LPG (includes orifice)	B069002	B069002	B069002	B069002	B069002	B069002	B069002	B069002
16	Manifold - NAT (includes orifice)	B069003	B069003	B069003	B069003	B069003	B069003	B069003	B069003
17	Electric Ignitor	B072218	B072218	B072218	B072218	B072218	B072218	B072218	B072218
18	Valve - LPG	B076790	B076790	B076790	B076790	B076790	B076790	B076790	B076790
18	Valve - NAT	B076789	B076789	B076789	B076789	B076789	B076789	B076789	B076789
19	Shelf Pin	B073963	B073963	B073963	B073963	B073963	B073963	B073963	B073963
20	Control Panel Assembly (with label)	B100751	B100751	B100751	B100751	B100751	B100751	B100751	B100751
20	Control Panel Label (not shown)	B072686	B072686	B072686	B072686	B072686	B072686	B072686	B072686
21	Valve Knob - Black	B070084	B070084	B070084	B070084	B070084	B070084	B070084	B070084
22	Grill Body Bottom (with Hinge and Bridge Pins)	B100460	B100462	B100461	B100460	B100461	B100460	B100460	B100460
22	Grill Body Bottom (casting only)	B100463	B100466	B100465	B100463	B100465	B100463	B100463	B100463
23	Control Panel Shield	B100730	B100730	B100730	B100730	B100730	B100730	B100730	B100730
24	Ignitor Ground Wire	B072684	B072684	B072684	B072684	B072684	B072684	B072684	B072684
25	Ignitor Grounding Lug	B069747	B069747	B069747	B069747	B069747	B069747	B069747	B069747
26	Collector Box Spacer	B069743	B069743	B069743	B069743	B069743	B069743	B069743	B069743
27	Collector Box	B100446	B100446	B100446	B100446	B100446	B100446	B100446	B100446
28	Flavor Screen Rack	N/A	N/A	N/A	N/A	N/A	N/A	N/A	N/A
29	Flavor Screen	N/A	N/A	N/A	DPA103	DPA103	DPA103	N/A	DPA103
30	Smoker/Shutter (includes Actuator Arm & Knob)	N/A	N/A	N/A	N/A	N/A	DPA100	N/A	N/A
31	Actuator Arm - Smoker/Shutter	N/A	N/A	N/A	N/A	N/A	B100408	N/A	N/A
32	Knob - Smoker/Shutter Knob	N/A	N/A	N/A	N/A	N/A	B100098	N/A	N/A
33	Hose & LPS Regulator	B069756	B069756	B069756	B069756	B069756	B069756	B069756	B069756
34	Hardware Package - LPG (not shown)	B101235	B101235	B101235	B101235	B101235	B101235	B101235	B101235
34	Hardware Package - NAT (not shown)	B100853	B100853	B100853	B100853	B100853	B100853	B100853	B100853

PREMIUM "P" SERIES PARTS LIST (cont.)

Index Number	Part Description	Part Number						
		P4BL P4BLN	P4HG P4HGN	P4GY P4GYN	P4FBL P4FBLN	P4FGY P4FGYN	P4BLW P4BLWN	P4FBLW P4FBLWN
1	Grill Body Top (with heat indicator, hinge, and bridge pins)	B073286	B076830	B073282	B073286	B073282	B073286	B073286
1	Grill Body Top (casting only)	B076621	B100151	B100149	B076621	B100149	B076621	B076621
2	Heat Indicator (stainless)	B076625	B076625	B076625	B076625	B076625	B076625	B076625
3	Lid Handle (stainless)	B070486	B070486	B070486	B070486	B070486	B070486	B070486
4	Foam Grip	B073097	B073097	B073097	B073097	B073097	B073097	B073097
5	Retract-A-Rack (stainless)	B072696	B072696	B072696	B072696	B072696	B072696	B072696
6B	Cooking Grid (3 piece Porcelain)	B100497	B100497	B100497	B100497	B100497	N/A	N/A
6C	Cooking Grid (2 piece Stainless Steel Rod)	N/A	N/A	N/A	N/A	N/A	B101321	B101321
7	Briquette Bag	B058122	B058122	B058122	N/A	N/A	B058122	B058122
8	Briquette Rack	B067449	B067449	B067449	N/A	N/A	B067449	B067449
9	Burner Assembly	DPP102	DPP102	DPP102	DPP102	DPP102	DPP102	DPP102
10	Radiation Shield (Heat & Wind Deflector)	DPP6SS	DPP6SS	DPP6SS	DPP6SS	DPP6SS	DPP6SS	DPP6SS
11	Bridge Pin	B057805	B057805	B057805	B057805	B057805	B057805	B057805
12	Hinge Pin	B057804	B057804	B057804	B057804	B057804	B057804	B057804
13	Lid Stop Kit	DPA106	DPA106	DPA106	DPA106	DPA106	DPA106	DPA106
14	Orifice - LPG (#55 drill)	B056649	B056649	B056649	B056649	B056649	B056649	B056649
14	Orifice - NAT (#48 drill)	B056647	B056647	B056647	B056647	B056647	B056647	B056647
15	Manifold Mounting Plate	B100517	B100517	B100517	B100517	B100517	B100517	B100517
16	Manifold - LPG (includes orifice)	B069002	B069002	B069002	B069002	B069002	B069002	B069002
16	Manifold - NAT (includes orifice)	B069003	B069003	B069003	B069003	B069003	B069003	B069003
17	Electric Ignitor	B072218	B072218	B072218	B072218	B072218	B072218	B072218
18	Valve - LPG	B076790	B076790	B076790	B076790	B076790	B076790	B076790
18	Valve - NAT	B076789	B076789	B076789	B076789	B076789	B076789	B076789
19	Shelf Pin	B073963	B073963	B073963	B073963	B073963	B073963	B073963
20	Control Panel Assembly (with label)	B100752	B100752	B100752	B100752	B100752	B100752	B100752
20	Control Panel Label (not shown)	B072197	B072197	B072197	B072197	B072197	B072197	B072197
21	Valve Knob - Black	B070084	B070084	B070084	B070084	B070084	B070084	B070084
22	Grill Body Bottom (with Hinge and Bridge Pins)	B073287	B076829	B073283	B073287	B073283	B073287	B073287
22	Grill Body Bottom (casting only)	B076622	B100150	B100148	B076622	B100148	B076622	B076622
23	Control Panel Shield	B100731	B100731	B100731	B100731	B100731	B100731	B100731
24	Ignitor Ground Wire	B072684	B072684	B072684	B072684	B072684	B072684	B072684
25	Ignitor Grounding Lug	B069747	B069747	B069747	B069747	B069747	B069747	B069747
26	Collector Box Spacer	B069743	B069743	B069743	B069743	B069743	B069743	B069743
27	Collector Box	B100446	B100446	B100446	B100446	B100446	B100446	B100446
28	Flavor Screen Rack	N/A	N/A	N/A	B100713	B100713	N/A	B100713
29	Flavor Screen	N/A	N/A	N/A	DPPA104	DPPA104	N/A	DPPA104
30	Smoker/Shutter (includes Actuator Arm & Knob)	N/A	N/A	N/A	N/A	N/A	N/A	N/A
31	Actuator Arm - Smoker/Shutter	N/A	N/A	N/A	N/A	N/A	N/A	N/A
32	Knob - Smoker/Shutter Knob	N/A	N/A	N/A	N/A	N/A	N/A	N/A
33	Hose & LPS Regulator	B069756	B069756	B069756	B069756	B069756	B069756	B069756
34	Hardware Package - LPG (not shown)	B101235	B101235	B101235	B101235	B101235	B101235	B101235
34	Hardware Package - NAT (not shown)	B100853	B100853	B100853	B100853	B100853	B100853	B100853

GRILL ASSEMBLY

Before You Begin

All Broilmaster grills require some assembly and installation. Follow all instructions unless noted to apply only to other specific models.

If you purchased an accessory with your Broilmaster, follow the instructions provided with the accessory for assembly and installation. If an instruction refers to a step that is not required for your grill model, please continue to the next step.

Each step of the installation is illustrated. In each illustration parts are identified with “Key” numbers. Key numbers appear in parenthesis after a part name is mentioned for the first time in the instructions and are labeled on the illustrations. You can reference each part by its key number on the Parts List if you need help in identifying a part.

Compare the parts found in the shipping container to the parts list provided. If any parts are missing contact your Broilmaster® dealer before beginning assembly.

CAUTION: FOR YOUR SAFETY

Parts may have sharp edges. Wear leather work gloves and handle parts carefully during the unpacking, assembly and installation.

Recommended Tools

These items are recommended for the assembly of your grill:

Do NOT use power tools.

- Phillips screwdriver
- Adjustable wrench set
- Socket set
- Soapy water solution (to test for leaks)
- Liquid soap (for foam grip)

Grill Mountings

Assemble your base option before assembling your Broilmaster® grill head.

Refer to the Broilmaster® Cart, Base, and Post instructions provided with each accessory for assembly, installation, and mounting procedures.

GRILL ASSEMBLY

Ignitor Assembly

Slide the collector box spacer (26) and nut (provided on assembly) onto the collector box shaft and tighten. See **Figure 1**.

Note: Peel protective film from control panel label before installing ignitor.

Figure 1

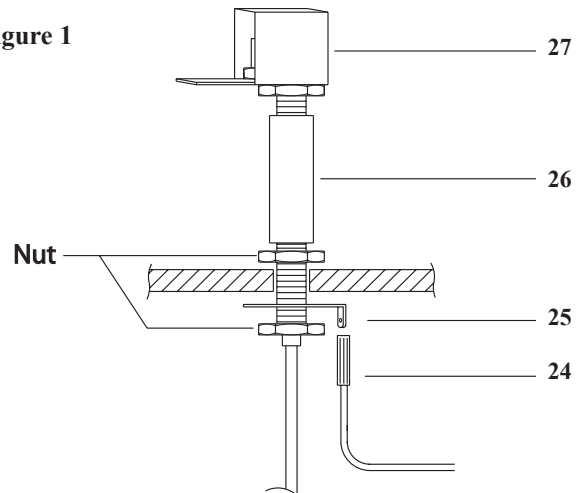
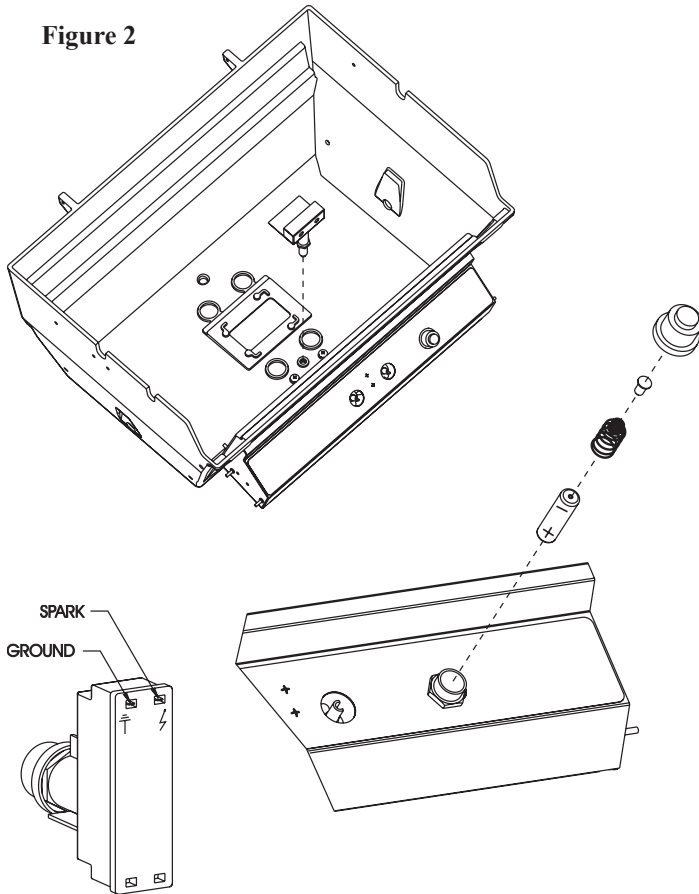

Figure 2



Installing the Ignitor

Caution: Do not cut or damage ignitor wire.

Carefully thread the end of the ignitor wire through the center hole in the grill bottom. Slide the ground lug (25) over the ignitor wire and fasten with nut provided.

Attach one end of the ground wire (24) to the terminal on the rear of the electronic ignitor. Attach the remaining end to the ground lug. See **Figures 1 and 2**.

Attach ignitor wire to the spark terminal on the rear of the electronic ignitor.

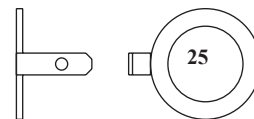

GRILL ASSEMBLY

Figure 3

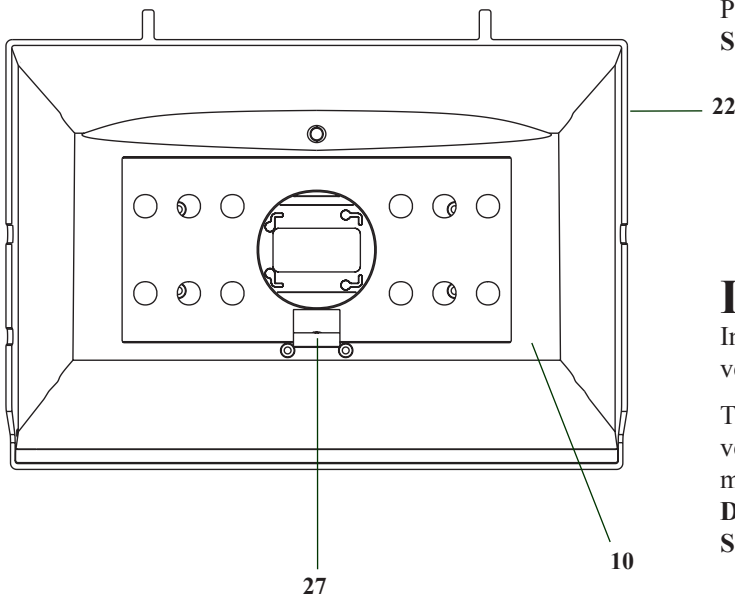

Radiation Shield

Place the radiation shield (10) in the grill bottom (22). See Figure 3.

Installing the Burner

Insert the burner assembly (9) into the grill bottom (22) with the venturi tubes facing the front of the grill. See Figure 4.

The gas jets from the control valve will be inside the ends of the venturi tubes when properly installed. Attach venturi to manifold mounting bracket (15) with two stainless steel hex washer screws. **Do NOT use power tools.** See Figure 5.

Figure 4

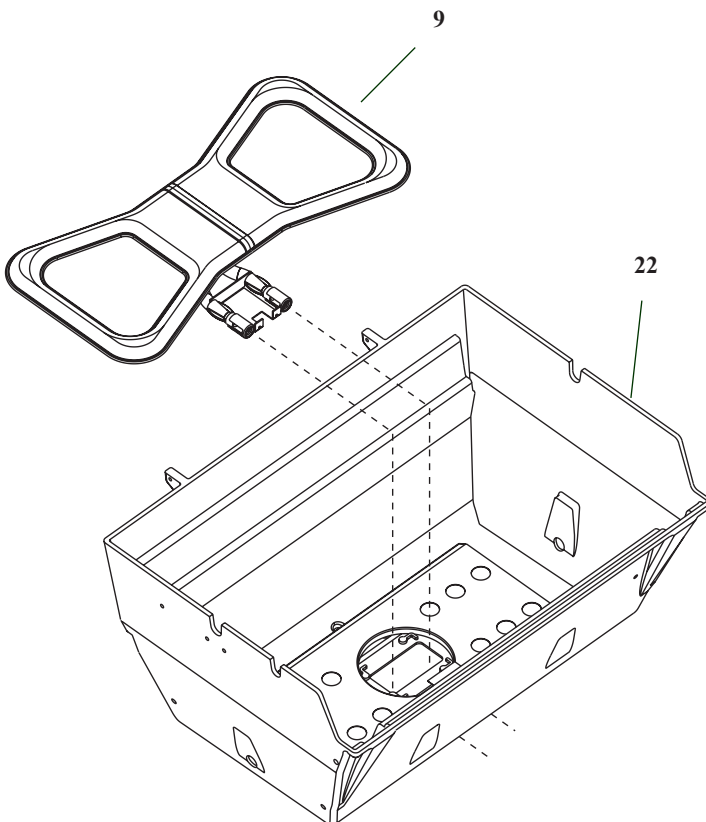
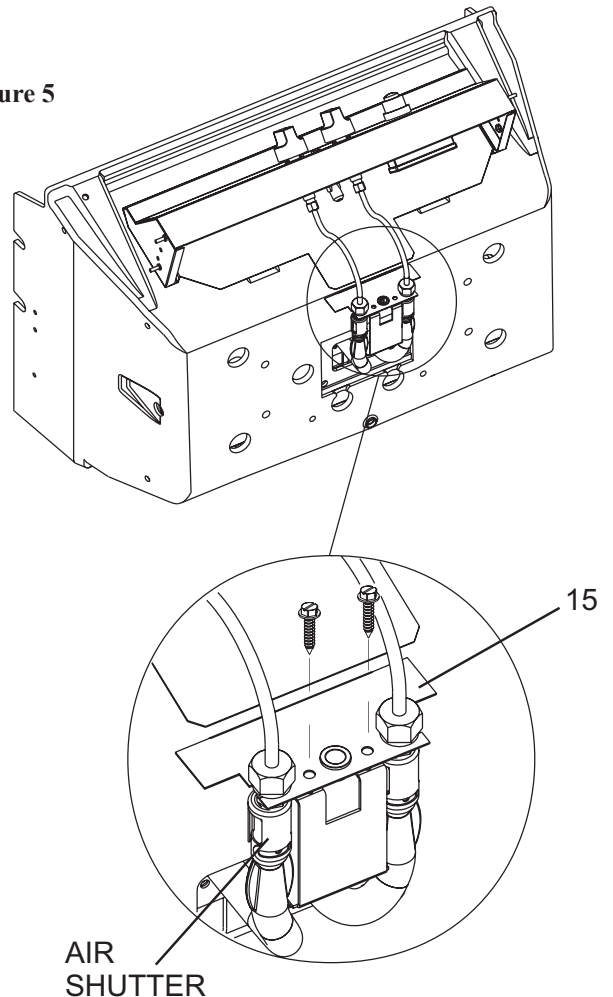

Figure 5



GRILL ASSEMBLY

Handle

For your added comfort a foam grip (4) has been provided. See Figure 7.

Tip: For ease of installation, slightly lubricate the front handle with liquid soap before pushing the foam grip into place.

Fasten the front handle (3) to the grill lid (1) with two #10-24 x 1" screws. See Figure 6.

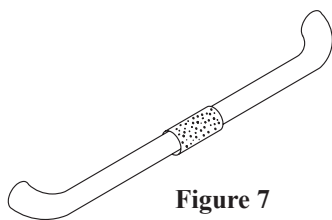
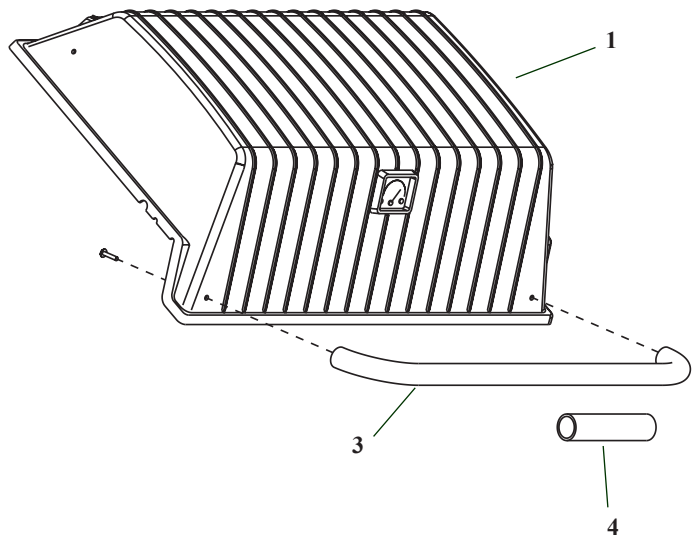

Figure 7

Figure 6



Install side shelves or side burner to side of grill at this time.

Figure 8

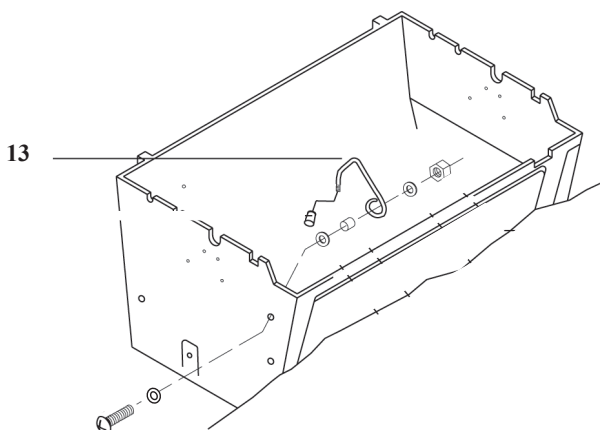

Lid Stop

Attach the lid stop assembly to the grill bottom as shown. See Figure 8.

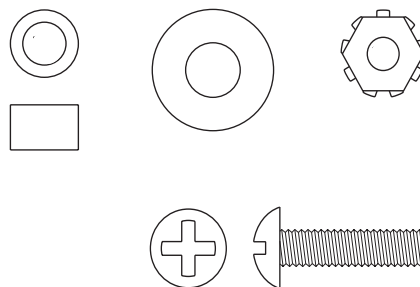

GRILL ASSEMBLY

Installing Racks

Place the briquet rack (8) or flavor screen rack (28) on the burner assembly.

Position the flavor screen (29) on to flavor screen rack (28) or the ceramic briquets (7) evenly on the briquette rack without overlapping.

For Smoker Shutter installation see DPA100 manual included with your P3S grill.

Set the multilevel cooking grids. See Figure 9.

Installing Char-Master Briquets

Individually place the 'Char-Master' briquets in a single layer evenly on your grill's briquet rack; DO NOT dump them onto the briquet rack. A single layer of 'Char-Master' briquets is all that's needed. DO NOT overlap or stack the briquets. See Figure 9.

After properly placing the 'Char-Master' briquets on your grill's briquet rack, there may be some briquets left over. Save them for future use.

Before cooking, always preheat the grill as directed by the grill's operating instructions. Hot briquets cause better, quicker cooking and better flavor.

Cleaning

Routine preheating and routine burn-off (also called postheating) of a grill will clean the 'Char-Master' briquets. Periodically turn the briquets over while they are cool.

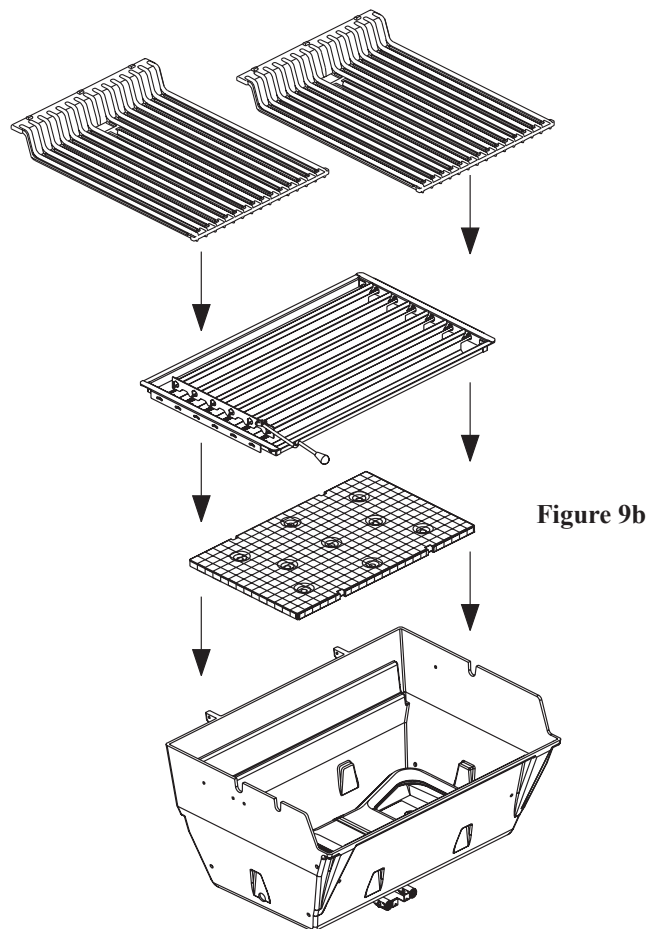
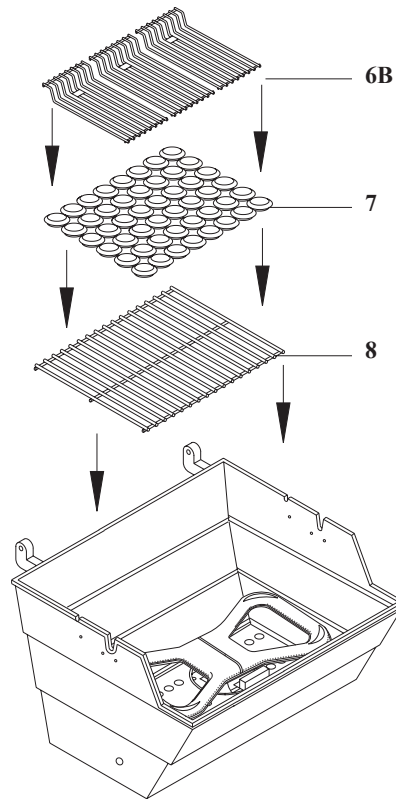

PROPANE GAS GRILLS

Grill Location

When choosing the ideal location for your Broilmaster® Premium Gas Grill, remember this grill is designed for outdoor use ONLY.

You should never install or operate your grill in any building, garage, or other enclosed area.

For your safety, this grill should not be installed or operated under any combustible materials, such as carports, covered porches, awnings, or overhangs.

Never install or operate your grill in or on any recreational vehicle or boat.

CAUTION: The installation and operation of this grill at clearances less than specified below may lead to the possibility of fire, property damage, or personal injury.

A minimum clearance of sixteen inches (16") is required from the sides of the grill to any combustible material.

A minimum clearance of eighteen inches (18") is required from the back of the grill to any combustible material.

Some examples of combustible materials are a wall, a fence, patio furniture, or the wall of your home.

The area surrounding the grill should be clear to ensure proper ventilation. Do not obstruct the flow of combustion and ventilation air in any way. The ventilation openings on the propane cylinder enclosure must also remain free and clear of debris.

Portable grills should be level and positioned away from direct wind prior to each use.

WARNING: Do not install or operate this grill where gasoline or other flammable materials are used or stored. Failure to comply with this warning could result in explosion or fire causing property damage or personal injury.

Gas Type

Never use Liquid Propane (LP) gas with a grill designed for Natural gas, or Natural gas with a grill designed for Liquid Propane gas. The type gas required for your grill can be determined from the product identification label located on the grill's control panel. Questions regarding different types of gases should be directed to your gas supplier.

Cylinder Requirements

Your Broilmaster® Premium Gas Grill requires a standard twenty (20) pound propane gas cylinder.

The maximum height allowable for a replacement cylinder is approximately twelve (12") inches (30.5 centimeters).

The propane gas cylinder used must be:

1. Constructed and marked in accordance with the specifications for LP gas cylinder of the U.S. Department of Transportation (D.O.T.) or the National Standard of Canada, CAN/CSA-B339, Cylinders, Spheres, and Tubes for Transportation of Dangerous Goods; and Commission as applicable.
2. Provided with a listed overfilling protection device (OPD).
3. Provided with a listed safety device having direct access with the vapor space of the cylinder and the cylinder supply system must be arranged for vapor removal.
4. Provided with a shutoff valve terminating in a valve outlet as specified in the Standard for Compressed Gas Cylinder Outlet and Inlet Connections, ANSICGA-V-1.
5. Provided with a plug to effectively seal off the cylinder outlet when the cylinder is being stored or transported.
6. Provided with a collar to protect the cylinder valve.

Caution: Do not use a propane gas cylinder which has a capacity greater than twenty (20) pounds with this grill and side burner.

PROPANE GAS GRILLS

Propane Cylinder Safety

Liquid Propane (LP) gas has a long history of safe use when the safety precautions provided in this manual are followed.

Failure to follow these safety precautions could result in a fire or explosion causing property damage or personal injury.

Propane gas cylinders should always be handled, stored, and transported with extreme caution in a secured upright position.

Never attempt to use or repair a propane gas cylinder that has been damaged. Never attempt to use or repair a cylinder with a faulty or damaged valve outlet. A cylinder that has been dropped, dented, or otherwise damaged must be replaced.

A propane gas cylinder should never be transported in the passenger area of a vehicle.

Keep cylinders out of direct sunlight and never apply any other source of direct heat to them.

When refilling your cylinder, always insist on a reputable, qualified gas dealer. Your propane gas cylinder is filled by weight, and should never exceed eighty percent (80%) of its weight limit. If the cylinder is not completely empty, the gas dealer must make necessary adjustments to ensure it is not overfilled. Never use an overfilled Propane gas cylinder.

Cylinder Storage

Your grill must be stored outdoors in a well ventilated area if the cylinder is attached to it.

Disconnected cylinders must have a threaded valve plug tightly installed and must not be stored in any building, garage, or other enclosed area.

Flammable materials (gasoline, grill covers, etc.) must not be stored in the cylinder enclosure.

Always store Propane cylinders in a secured upright position, out of the reach of children.

Connection Requirements

Caution: Never use Liquid Propane (LP) gas in a grill designed for Natural gas, or Natural gas in a grill designed for Liquid Propane gas. Questions regarding different types of gases should be directed to your local gas supplier.

Installation must conform to local codes or, in the absence of local codes, with the National Fuel Gas Code, ANSI Z223.1. In Canada, installation shall be in accordance with CAN/CGA-B149.2 Propane Installation Code, or CAN/CGA-B149.1 Natural Gas Installation Code, and local codes where applicable. Consult your local gas supplier or propane gas dealer for code regulations and recommended procedures.

Warning: Broilmaster® Premium Gas Grills require Liquid Propane (LP) cylinders equipped with an Overfill Protection Device (OPD). An overfilled or improperly filled Propane cylinder can be dangerous.

Always use the pressure regulator and hose assembly supplied with your Propane gas grill.

Note: Not all valve and cylinder combinations are compatible. Check warning tag on valve and cylinder as well as external fitting threads.

All Broilmaster® pressure regulators and hose assemblies require Propane cylinders with a Type 1 connection device as illustrated. See Figure 10.

Figure 10

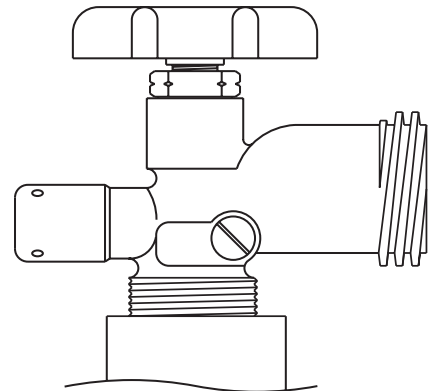

PROPANE GAS GRILLS

Pressure Regulator and Hose Assembly

The pressure regulator has an outlet pressure of not more than eleven (11") inches water column. It must be connected to the Propane gas cylinder's female valve outlet before the grill can be operated.

Caution: Operation of a Propane gas grill without the pressure regulator and hose assembly will cause gas leaks which could lead to fire or explosion, resulting in property damage or personal injury.

The pressure regulator's fitting must remain clean and free of nicks and scratches. A dirty, nicked or scratched fitting can cause a gas leak, resulting in an explosion or fire. Use only genuine Broilmaster® replacement parts unless otherwise specified by the manufacturer.

Connecting to Propane Gas / Cylinder Retention Means

ATTENTION: Propane gas cylinders that are acceptable for use with this grill must comply with Cylinder Requirements, Page 14, and Connection Requirements, Page 15.

Position the cylinder in the opening in the bottom of the cart and secure with the cylinder retaining bracket. **See Figure 11.**

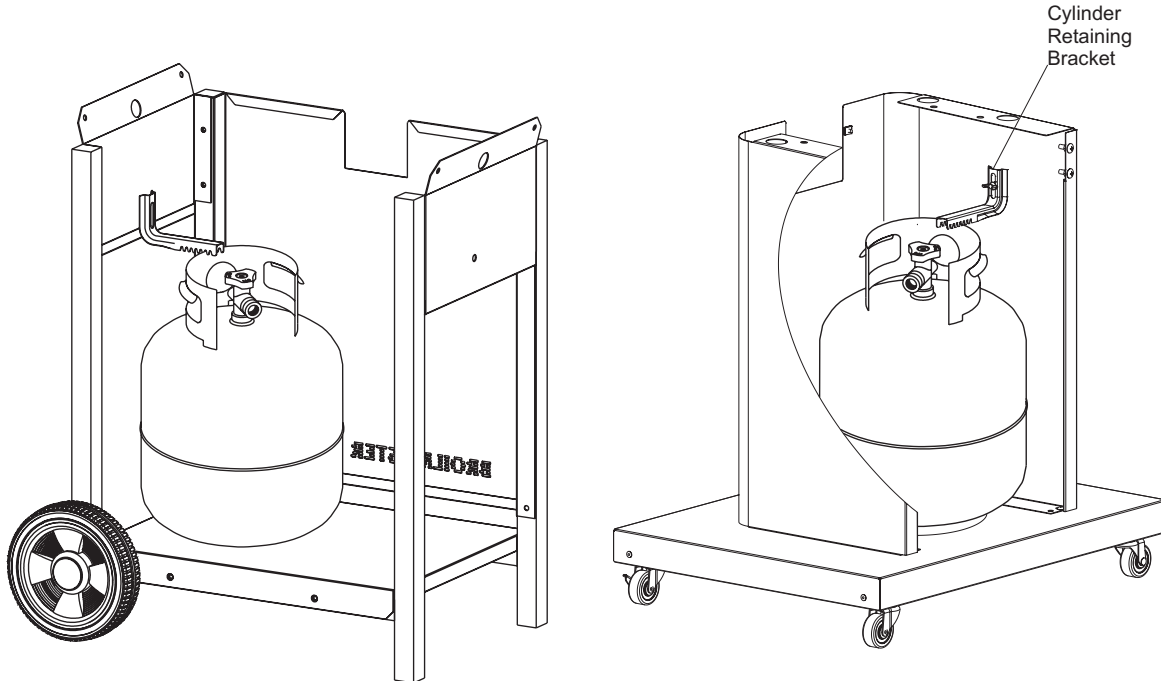

Figure 11

Attach the pressure regulator to the Propane gas cylinder's valve using the plastic handwheel. Tighten in a clockwise motion to achieve a gas tight seal. **See Figure 12.**

Caution: Do not use a wrench or any other tool to tighten. Use of a wrench or other tool will damage the plastic handwheel.

To disconnect the Propane gas cylinder, turn OFF the cylinder's valve and the grill's control valve. Remove the regulator by turning the plastic handwheel counterclockwise.

Caution: Assure hose does not touch the casting or mounting components.

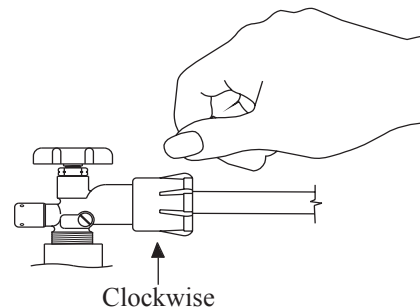

Figure 12

GAS CONVERSION

Gas Conversion

Propane grills include a conversion kit for natural gas. If you have a natural grill and wish to convert it to propane you will need to purchase the optional conversion kit BCK1003.

Begin by removing all the components from the inside of your grill. Locate and remove the orifice hoods mounted on the underside of the grill body, using 2 wrenches as shown. See **Figure 13**.

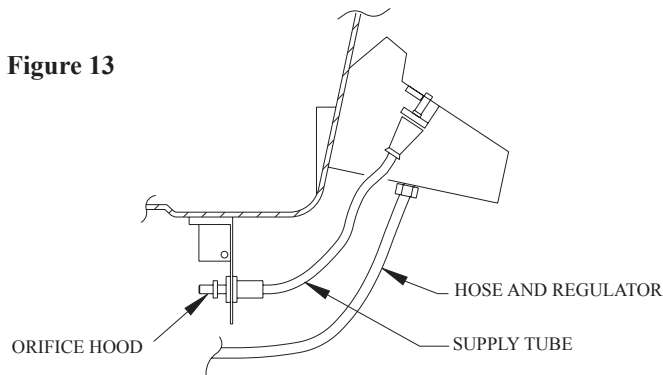

Figure 13

Before installing the natural hoods, inspect them for damage and note the number stamped on the side. The correct hood will be marked 48".

The hoods are self-sealing, requiring no additional pipe sealant. If you wish to use sealant, take care to add it to the threads only to avoid blocking the orifice.

Thread the hoods onto the supply tubes leaving about a 1/8" gap between the hood and the locking nut. See **Figure 14**.

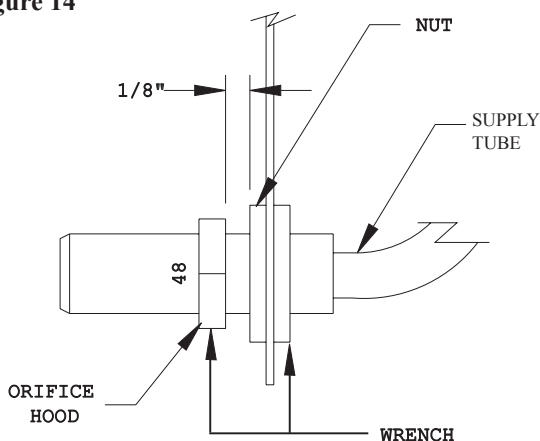

Figure 14

Remove the hose and regulator from the valve.

Replace the components inside of your grill.

Remove the knobs from the valve assembly and locate the adjustment screws on the inside of the valve stem. Using a small screw driver, turn the screws clockwise until screw bottoms, then turn the screws four (4) FULL turns counterclockwise. Do not back the screws out more than 4 1/2 turns or a leak may result.

See **Figure 15**.

Connect the grill to the natural gas supply.

Important: Before lighting your grill, check the gas connections and the adjustment screws for leaks using a soapy water solution.

Caution: Never use this or any gas appliance which may be leaking gas.

Replace the knobs.

Figure 15

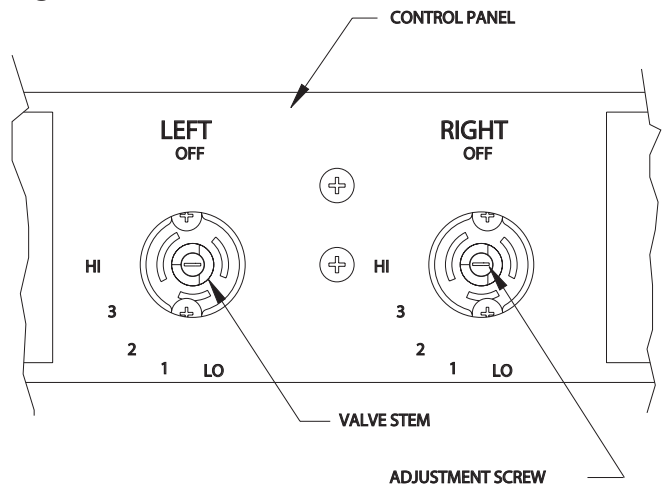

Place the completed conversion label adjacent to the product identification label, located on the control panel (26).

NOTE: When converting your grill to Natural gas and your incoming gas pressure is below 7" (water column), a DPA105 regulator kit can be purchased.

NATURAL GAS GRILLS

Grill Location

When choosing the ideal location for your Broilmaster® Premium Gas Grill, remember this grill is designed for outdoor use ONLY.

You should never install or operate your grill in any building, garage, or other enclosed area.

For your safety, this grill should not be installed or operated under any combustible materials, such as carports, covered porches, awnings, or overhangs.

Never install or operate your grill in or on any recreational vehicle or boat.

CAUTION: The installation and operation of this grill at clearances less than specified below may lead to the possibility of fire, property damage, or personal injury.

A minimum clearance of sixteen inches (16") is required from the sides of the grill to any combustible material.

A minimum clearance of eighteen inches (18") is required from the back of the grill to any combustible material.

Some examples of combustible materials are a wall, a fence, patio furniture, or the wall of your home.

The area surrounding the grill should be clear to ensure proper ventilation. Do not obstruct the flow of combustion and ventilation air in any way. The ventilation openings on the propane cylinder enclosure must also remain free and clear of debris.

Portable grills should be level and positioned away from direct wind prior to each use.

WARNING: Do not install or operate this grill where gasoline or other flammable materials are used or stored. Failure to comply with this warning could result in explosion or fire causing property damage or personal injury.

Gas Type

The type gas required for your grill can be determined from the product identification label located on the grill's control panel. Questions regarding different types of gases should be directed to your local gas supplier.

Caution: Never use Liquid Propane (LP) gas in a grill designed for Natural gas, or Natural gas in a grill designed for Liquid Propane gas. Questions regarding different types of gases should be directed to your local gas company.

Connection Requirements

Installation must conform to local codes or, in the absence of local codes, with the National Fuel Gas Code, ANSI Z223.1. In Canada, installation shall be in accordance with CAN/CGA-B149.2 Propane Installation Code, or CAN/CGA-B149.1 Natural Gas Installation Code, and local codes where applicable. Contact your local gas company for code regulations, recommended procedures, and the installation of your grill's gas supply line.

Broilmaster® grills are not equipped with pressure regulators. Your gas grill operates at a manifold pressure of seven (7") inches water column.

Connect cart mounted Natural gas grills to a pre-installed gas supply line using the twelve (12') foot flexible hose and quick disconnect kit which can be purchased from your local dealer.

Caution: The grill and its individual shutoff valve must be disconnected from the gas supply piping system during any system pressure testing at test pressures in excess of 1/2 PSIG.

Caution: The grill must be isolated from the gas supply piping system by closing its individual manual shutoff valve during any pressure testing of the gas supply piping system at test pressures equal to or less than 1/2 PSIG.

OPERATION - PROPANE & NATURAL GAS GRILLS

Checking for Gas Leaks

Check for gas leaks every time you connect your Broilmaster® propane gas grill to a Propane gas cylinder, when a connected cylinder has not been used recently, or when either a natural or propane grill is being used for the first time.

Caution: Do not use an open flame when checking for leaks. Checking for leaks with an open flame may lead to a fire or explosion, resulting in property damage or personal injury.

To check for gas leaks:

1. Use dish washing liquid and a little water to make a soapy solution.
2. Turn OFF the knob on the control panel.
3. Turn ON the gas at the supply or cylinder. A hissing sound indicates a leak. Turn OFF the gas and repair the leak.
4. Apply the soapy water solution to all gas connections.
5. Look for bubbles. Bubbles indicate a leak.
6. If there are bubbles turn OFF the gas and repair the leak.
7. Turn the gas back ON and repeat the above procedures until all leaks are repaired.

Air Shutter Adjustment

The venturi air shutter(s) are preset at the factory so that after five minutes the burner flames are blue with well defined cones. If, after five minutes the flame is yellow, or there is a gap between the burner and the flame, adjust the venturi air shutter as follows:

1. Turn gas OFF and let the burner cool.
2. Loosen shutter set screw
3. Close the air shutter to the minimum opening. **See Figure 5.**
4. Light the burner, wait five minutes and then carefully open the air shutter until the flame is blue and well defined.
5. Retighten the set screw.

Operating Instructions

Using the Ignitor

Caution: If a burner fails to light after 5 seconds, turn the burner OFF for 5 minutes, to allow the gas to clear, then try again.

1. Turn knob on the grill CLOCKWISE to the OFF position.
2. Turn ON gas at the source.
3. With the grill lid open, push and turn the burner control knob COUNTERCLOCKWISE to Hi.
4. Push and hold the ignitor button until the burner lights (approximately 5 seconds).
5. If a burner does not light, turn OFF all gas and refer to the Troubleshooting section of this manual.

Operating Instructions

Using Matches

Caution: If a burner fails to light after 5 seconds, turn the burner OFF for 5 minutes, to allow the gas to clear, then try again.

1. Turn knob on the grill CLOCKWISE to the OFF position.
2. Turn ON gas at the source.
3. Open the grill lid.
4. Insert a burning long wooden match through the lighter hole on either side of the grill.
5. Turn the burner control knob COUNTERCLOCKWISE to HI.
6. If a burner does not light, turn OFF all gas and refer to the Troubleshooting section of this manual. **See Figure 16.**

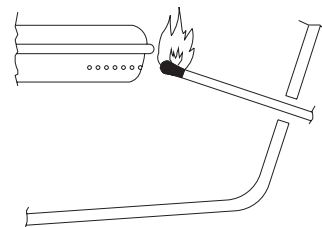

Figure 16

OPERATION

Before Cooking

Before cooking on a grill for the first time, it should be broken in to burn off any oil residue from the manufacturing process.

1. Raise the grill lid.
2. Light grill burner.
3. Burn on HI for ten minutes.
4. Close the lid and burn on HI for an additional ten minutes.
5. Turn OFF gas. The grill is now ready for use.

Preheating

Before cooking on a gas grill, allow the grill to preheat on HI for 5 minutes with the lid closed.

This uses very little fuel and provides better flavor.

Cooking

Broilmaster® is happy to provide a cookbook with each of its grills. The cookbook contains helpful cooking tips and instructions as well as great tasting recipes for preparing many delicious foods on your grill.

Electrical Accessories

If an electrical accessory (e.g. rotisserie) is used on your grill, the accessory must be electrically grounded in accordance with local codes or, in the absence of local codes, with the National Electric Code, ANSI/NFPA 70. In Canada, the electrical accessory must be electrically grounded in accordance with the applicable section of the current Canadian Electrical Code, CSA C22.1.

Any electrical accessory should be equipped with a three-prong (grounding) plug, and plugged into a properly grounded three-prong receptacle or wall outlet. Do not cut or remove the grounding prong from the plug.

If an extension cord is required, use only a three-prong cord and plug into a properly grounded receptacle as described above.

Do not expose an electrical accessory to water. Avoid using any electrical accessory in wet weather as it may present a shock hazard.

Keep any electrical cord and fuel supply hose away from all heated surfaces.

MAINTENANCE

Cleaning the Grill

Caution: To prevent injury, use care when cleaning a hot grill.

Note: Do not use a commercial cleaner on the cooking grid. Do not brush grids while they are hot. Do not scrape grids.

For baked on residue use a brass (NOT STEEL) brush on the cooking grid and other components.

Burn Off

This process is much like that used in self-cleaning ovens and is most efficient when completed after each use of the grill.

Caution: Do not open the grill during the burn off process. Opening the grill during the burn off process may cause a sudden grease fire flare up that could burn your face and arms. Wait until the grill has cooled before opening.

1. Turn gas knob to HI. Close lid and allow the grill to burn for ten minutes, or until no smoke is present. Do not allow the grill to burn for more than 30 minutes.
2. Turn gas knob and supply to OFF and allow the grill to cool.
3. Wipe COOL grill with a damp cloth to remove soot.

Grill Bottom

Periodically remove cooking grids and flare guard to clean the interior of the grill. Scrape off baked on residue with a putty knife or brass brush and rinse with water. Clean the bottom air holes with a small knife.

Burner Maintenance

Stainless steel burners often turn reddish brown after use. This does not effect the performance of the grill. When cleaning the interior of the grill, remove the burners and clean with a brass brush. Wash with water and a mild detergent.

Grease Tray

Empty periodically. Replacement tray liners can be purchased at most supermarkets where disposable aluminum baking pans are displayed.

Venturi Tubes

The venturi tubes allow air and gas to mix prior to burning, thus ensuring an efficient flame. Spiders or other small insects may build webs or nests inside the tubes obstructing air flow. Fire, or flashback, can occur, in and/or around obstructed venturi tubes and can cause damage to components beneath the grill or an unsafe condition. To reduce risk, inspections and cleaning should be performed at least twice monthly when spiders are active. If the grill has been unused for an extended period of time inspect the tubes before using the grill.

Clean venturi tubes as follows:

1. Remove the cooking grids and briquette rack.
2. Remove the burner from the grill.
3. Lay the burner face down and remove the four retaining screws from the venturi tube plate and the burner. **See Figure 17.**
4. Use a small flexible brush to remove any debris for the tube(s).
5. Flush with water.
6. Allow the tube(s) to dry before reinstalling.
7. Reinstall the venturi tubes and burner.

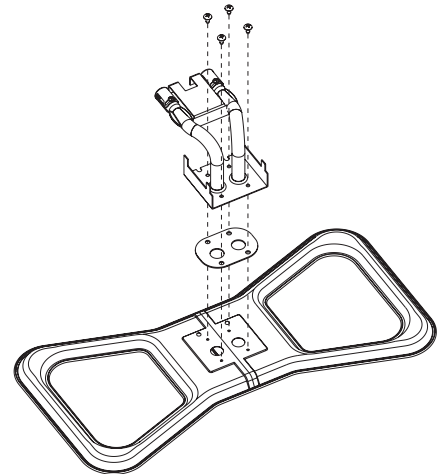

Figure 17

Exterior

Clean regularly with a solution of mild detergent and hot water. Touch-up paint is available from your dealer. Broilmaster® protective covers are recommended. Stainless steel components can be easily cleaned with a spray-on stainless steel cleaner found in most hardware stores.

Briquettes

If the briquettes did not come clean during burn off, after cooling turn them over. The residue will burn off during warm-up for the next use.

TROUBLESHOOTING

Although the manufacturer has attempted to ensure that your grill will operate properly and satisfactorily, sometimes problems do arise. The following troubleshooting guide lists several possible problems and their probable cause and solution.

Problem	Cause	Solution
Burner will not light.	Gas injector not inserted in venturi tube.	Realign/engage gas injector with the venturi tube.
	Clogged gas injector.	Remove gas injector from gas control assembly and clean.
	Obstruction in gas line.	For propane models, ensure gas valve on cylinder is OFF. Remove flexible hose and blow out any debris.
	Spider webs in venturi tubes.	Clean venturi tubes. See Maintenance Section.
	Misalignment of collector box and burner.	Position electrode properly. Clean collector box.
	Out of gas	Refill LP gas cylinder. If natural model, turn on gas at source.
	Dead battery.	Replace with AA Alkaline battery.
Inadequate grill temperature.	Poor combustion.	Adjust air shutter.
	Misalignment of venturi tube and gas injector.	Realign/engage gas injector with the venturi tube.
	Inadequate gas pressure.	Contact gas supplier for assistance.
	Incorrect orifice/valve setting.	Refer to gas conversion instructions in this manual.
Flames blow out.	Cold grill.	Preheat grill at least 5 minutes on HI with the grill lid closed.
	Misalignment of burner tube and gas injector.	Realign/engage gas injector with the burner tube.
	Poor combustion.	Adjust air shutter.
	Extreme wind.	Turn or shield grill.
Yellow flames.	Air shutter improperly set.	Open air shutter
	Spider webs in venturi tubes.	Clean venturi tubes. See Maintenance Section.
	Seasoning salts on burner.	Clean by washing burner with mild detergent.
	Oil film on burner.	Allow burner to operate on HI for 10-15 minutes.



WARRANTY TERMS

The Most Durable Grill Known
To Man

-
- Lifetime**
 - Aluminum Grill Housing (except paint)
 - Cast Stainless Steel Cooking Grids
 - Porcelain-Coated Cast Iron Cooking Grids
 - Stainless Steel - Cart, Mounting, Bowtie Burner, T3 Burner
 - Side Burner (DPSBSS), Side Burner Housing, and Warming Rack
 - Stainless Steel Built-In Components: Built-In Kit for Broilmaster P3/T3
 - Grill Head, Door Kit, Tilt-Out LP Tank Door and Vent Register Kit
 - 10-Year**
 - Built-In Kit (BSA) with Side Burner (DPASBC)
 - 5-Year**
 - Painted Electro-Galvanized Parts
 - Stainless Steel Smoker Shutter
 - 2-Year**
 - Porcelain-Coated Steel Briquet Racks
 - Stainless Steel Flavor Screen and Heat Shield
 - Chrome-Plated Warming Rack
 - 1-Year**
 - All Other Parts
 - Painted Steel - Unless specified above
 - Paint on Aluminum Grill Head

WHAT IS COVERED AND FOR HOW LONG

- From the date this Broilmaster Premium Grill is first purchased, we will make available at our factory a free replacement for any defective parts covered by this warranty on the following basis. Proof of purchase required. Warranty applies to original owner and is not transferable.

WHAT IS NOT COVERED

- Removal and reinstallation cost.
- Labor for replacement or repairs
- The costs of a service call to diagnose a problem
- Transportation and shipping cost.
- Grills and finishes damaged by abrasive cleaning, improper installation, improper storage, accident, misuse, abuse, alteration, commercial use, and unusually harsh environmental conditions. Harsh conditions could include, but are not limited to: continual seawater spray, direct contact with pool chemicals or lawn chemicals, direct contact with corrosive materials.
- Inoperable due to improper or lack of cleaning
- Damage from accident, misuse, alteration, abuse, improper installation or storage.

This warranty does not imply or assume any responsibility for consequential damages that might result from misuse, or improper installation of this cooking appliance.

This warranty does not cover claims which do not involve defective workmanship or materials.

A bill of sale, cancelled check, or payment record should be kept to verify purchase date and establish warranty period.

Note: Broilmaster, a Division of Empire Comfort Systems, Inc., has a policy of constantly improving quality and performance of its appliances; therefore, materials and specifications are subject to change without notice.

