



IMPORTANT

1. This booklet is an integral and essential part of the product and should be handed over to the user. Read the warnings contained in this booklet carefully as they give important indications regarding the safety of the installation, use and maintenance. Please preserve this booklet for any further consultation that may be necessary.
2. This icemaker should be destined only to the use for which it has been expressly conceived. Any other use should be considered improper and therefore dangerous. The manufacturer cannot be held responsible for eventual damage caused by improper, incorrect and unreasonable use.

CONTENTS

I. Specifications	4
A. Construction.....	4
B. Nameplate Rating	5
C. Dimensions/Connections	6
II. Installation Instructions	7
A. Checks Before Installation	7
B. Location	7
1. General.....	7
2. Built-In Installation Site.....	8
C. Setup.....	9
1. General.....	9
2. Water Supply and Drain Connections	10
3. Electrical Connections	11
4. Final Check List.....	11
D. Startup	12
E. Preparing the Icemaker for Long Storage.....	12
III. Cleaning and Maintenance.....	13
A. Cleaning and Sanitizing Instructions.....	13
1. Cleaning Solution.....	13
2. Cleaning Procedure.....	14
3. Sanitizing Solution.....	15
4. Sanitizing Procedure.....	15
B. Maintenance.....	19

Specifications



A. Construction

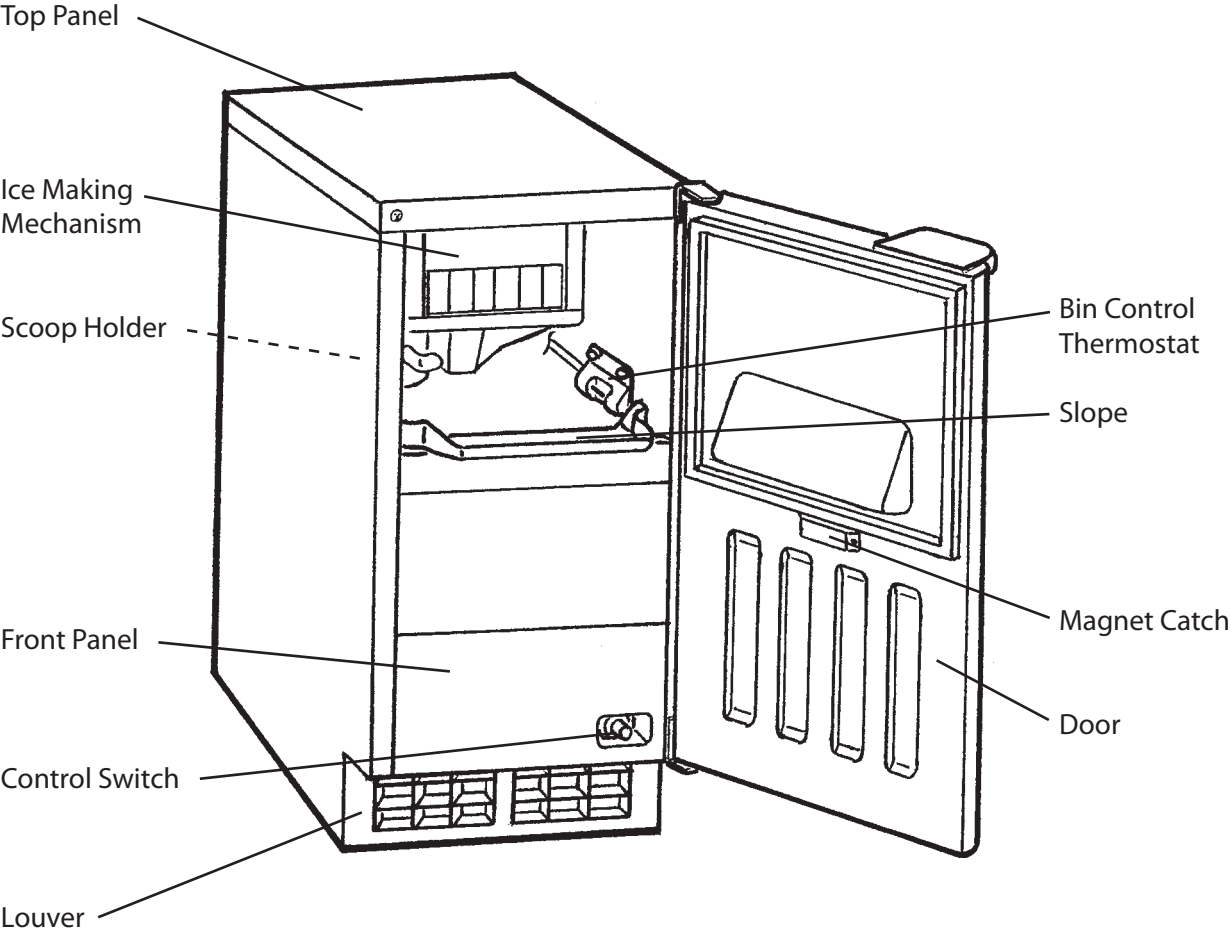



B. Nameplate Rating

LYNX ICE MACHINE



MODEL NUMBER	L15ICE
SERIAL NUMBER	
AC SUPPLY VOLTAGE	115-120/60/1
AMPERES	3.4 AMPS
DESIGN PRESSURE	HI-240PSI LO-120PSI
REFRIGERANT	134a 4.2 oz.

**MOTOR-COMPRESSOR THERMALLY PROTECTED
APPROVED FOR OUTDOOR USE**

Lynx Grills, Inc.
Commerce, Ca
www.lynxgrills.com



LISTED
ICE MAKER
946Z



COMPONENT

See the nameplate for electrical and refrigeration specifications. This nameplate is located on the rear panel.

We reserve the right to make changes in specifications and design without prior notice.



C. Dimensions/Connections

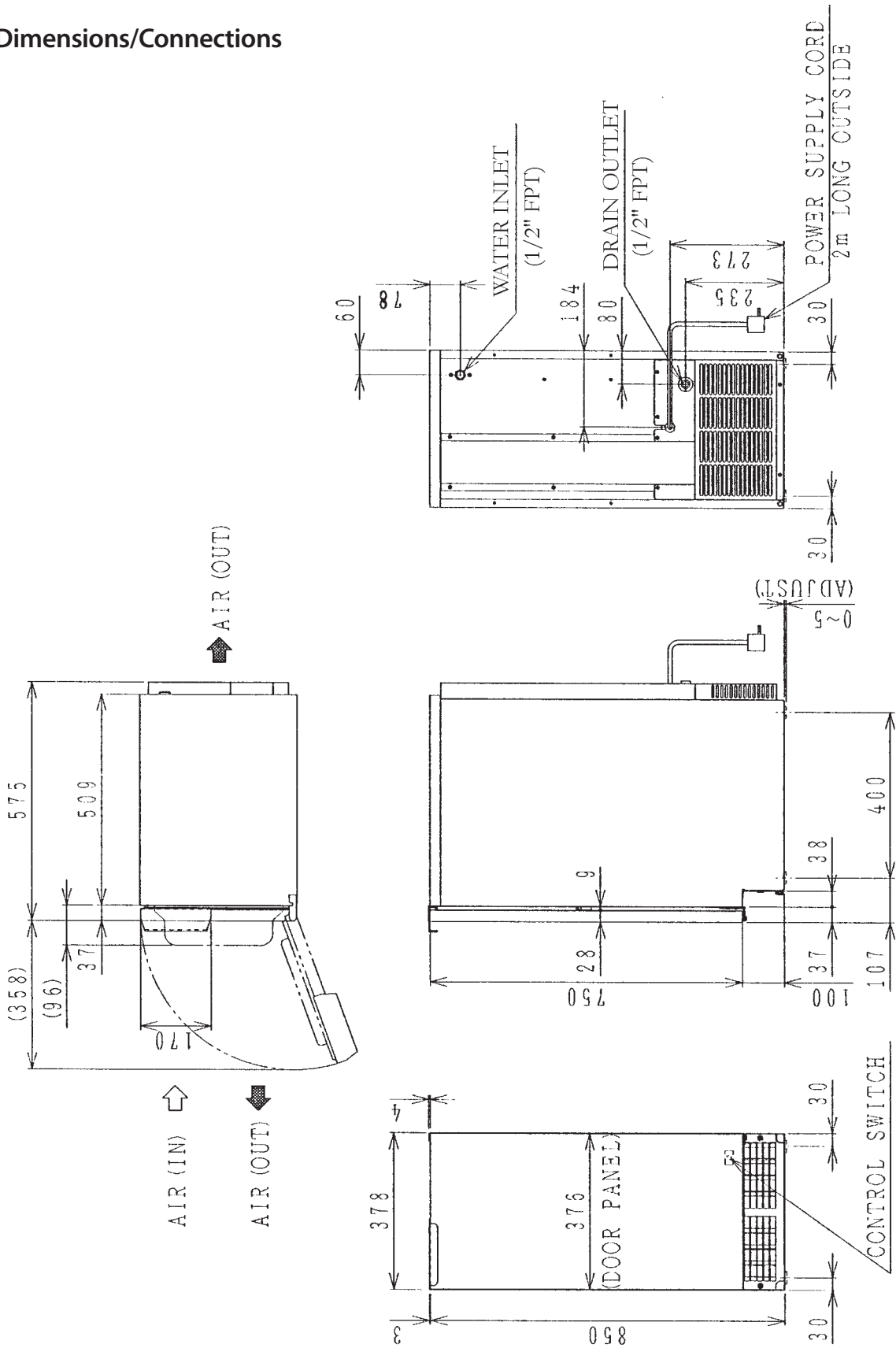

II. Installation Instructions



A. Checks Before Installation

Visually inspect the exterior of the shipping container and report any severe damage to the carrier.

WARNING

Remove shipping tape(s) and packing as follows. If any are left in the icemaker, it will not work properly.

IMPORTANT

1. Remove shipping tape holding the door.
2. Ensure all components, fasteners and thumbscrews are securely in place.

- Remove the package containing accessories. Remove shipping tape holding the separator.
- Check that refrigerant lines do not rub or touch lines or other surfaces.
- Check that the compressor is snug on all mounting pads.
- Remove the protective plastic film from the panels. If the icemaker is exposed to the sun or to heat, remove the film after the icemaker cools.
- See the nameplate on the rear panel, and check that your voltage supplied corresponds with the voltage specified on the nameplate.

B. Location

1. General

WARNING

Normal operating ambient temperature should be within 45°F (7°C) to 100°F (38°C); Normal operating water temperature should be within 45°F (7°C) to 95°F (35°C). Operation of the icemaker, for extended periods, outside of these normal temperature ranges may affect production capacity.

For best operating results:

- The icemaker should not be located next to ovens, grills or other high heat producing equipment.
- The location should provide a firm foundation for the equipment. Level the icemaker from side to side and front to rear.
- Avoid a site where dripping is not allowed.
- This icemaker will not work at subfreezing temperatures. To prevent damage to the water supply line, drain the icemaker when air temperature is below freezing.
- This icemaker requires no clearance on either side. But allow enough space at rear for water supply and drain connections and at least 15" (approx. 38 cm) clearance at front.



2. Built-in Installation Site

IMPORTANT

1. Do not let the weight of the counter rest on the icemaker.
2. Do not build in the icemaker in a corner where the door will hit other equipment such as an oven handle or where the icemaker cannot be pulled out for service.

INSTALLATION SPACE		
Height	Width	Depth
34" (864 mm) minimum	15" (381 mm) minimum	24" (610 mm) minimum

Between Two Cabinets

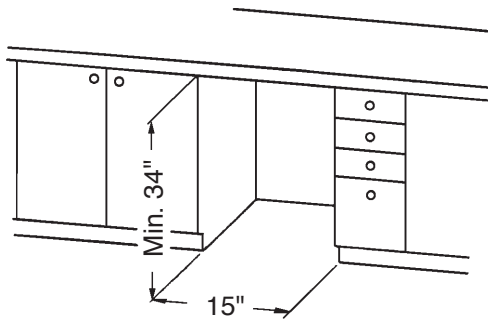

Between a Cabinet and an Open Space

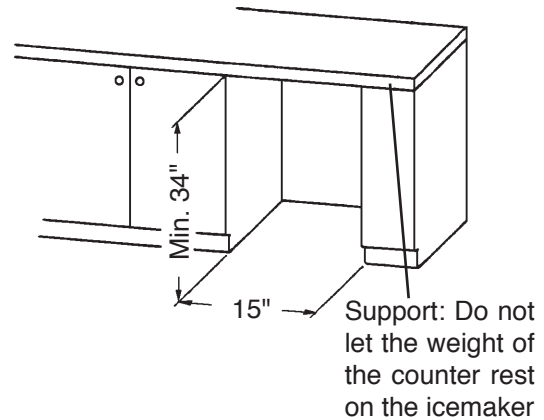

Between a Cabinet and a Wall or Tall Cabinet

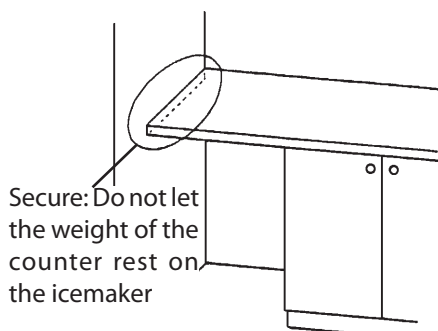

In a Corner

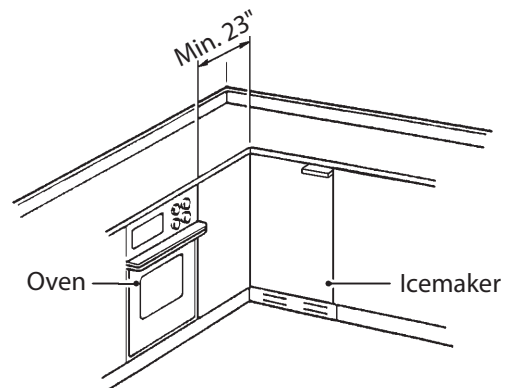



C. Setup

1. General

1. Make sure the unit is completely unpacked and that all shipping cartons, tapes and packing are removed BEFORE operating the unit. Be careful not to damage the exterior panels when handling the ice machine
2. Position the ice machine in a selected site. Clean the interior with soap and water and rinse thoroughly.
3. Make water supply and drain connections (See "2. Water Supply and Drain Connections.")
4. Plug in the ice machine. (See "3. Electrical Connections.")
5. If this is a stand-alone installation, go to step 6. Otherwise, build in the ice machine. Slowly push the lower part of the ice machine into place. Beware of adjacent equipment.

IMPORTANT

While building in the ice machine, do not damage the water supply and drain connections or the power cord.

6. Level the icemaker in both the left-to-right and the front-to-rear directions.
7. The perimeter where the machine touches the floor should be sealed with silicone for sanitation.



2. Water Supply and Drain Connections

WARNING

To prevent damage to the freezer mechanism, do not operate this icemaker when the water supply is OFF, or if the pressure is below the recommended minimum water pressure of 10 PSIG (0.7 bar). Stop the icemaker until proper water pressure is resumed.

- Water supply inlet is 1/2" FPT and must be connected only to a potable water supply.
- A water supply line shut-of valve and drain valve must be installed.
- Water supply pressure should be a minimum of 10 PSIG (0.7 bar) and a maximum of 113 PSIG (7.5 bar). If the pressure exceeds 113 PSIG (7.5 bar), use a pressure reducing valve.
- Drain outlet is 1/2" FPT.
- For gravity drain installation, drain must be 1/4" fall per foot (2 cm fall per meter) on horizontal runs to get good flow.
- An air gap of a minimum of 2 vertical inches (5 vertical cm) should be between the end of the drain pipe and the floor drain.
- The drain pipe must be installed properly to prevent a backflow into the storage bin.
- For condensate pump installation, refer to the instruction manual included with the pump.
- A plumbing permit and services of a licensed plumber may be required in some areas.
- This icemaker should be installed in accordance with applicable national, state and local regulations.

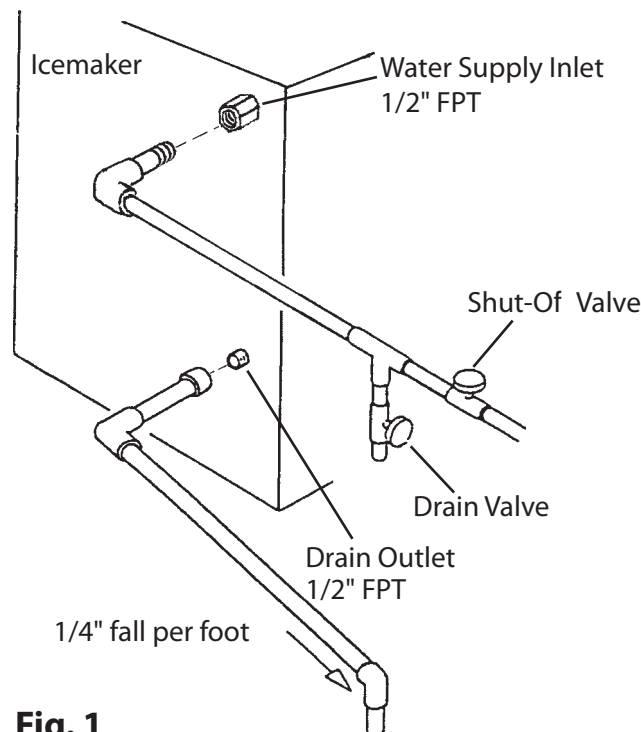

Fig. 1

To approved floor drain



3. Electrical Connections

WARNING

THIS APPLIANCE MUST BE GROUNDED.

This icemaker requires a ground that meets national and local electrical code requirements. To prevent possible severe electrical shock injury to individuals or extensive damage to equipment, install a proper ground wire to this icemaker. Remove the plug from the electrical outlet before any maintenance, repairs or cleaning is undertaken.

- This icemaker must be plugged into a separated power receptacle which has enough capacity. The maximum allowable voltage variation should not exceed ± 10 percent of the nameplate rating. See the nameplate.
- Usually an electrical permit and services of a licensed electrician are required.

4. Final Checklist

- 1) Is the icemaker level?
- 2) Is the icemaker in a site where the ambient temperature is within 45°F (7°C) to 100°F (38°C) and the water temperature within 45°F (7°C) to 95°F (35°C) all year around?
- 3) Have all shipping tape(s), string and packing been removed from the icemaker?
- 4) Are all components, fasteners and thumbscrews securely in place?
- 5) Have all electrical and piping connections been made?
- 6) Has the power supply voltage been tested or checked against the nameplate rating? Has a proper ground been installed to the icemaker?
- 7) Are the water supply line shut-of valve and drain valve installed? Has the water supply pressure been checked to ensure a minimum of 10 PSIG (0.7 bar) and a maximum of 113 PSIG (7.5 bar)?
- 8) Have the compressor hold-down bolts and all refrigerant lines been checked against vibration and possible failure?
- 9) Has the bin control thermostat been checked for correct operation? When the icemaker is running, hold an ice cube in contact with the bulb. The icemaker should stop within 3 to 10 seconds.
- 10) Has the user been given the Instruction Manual and instructed on how to operate the icemaker and the importance of the recommended periodic maintenance?
- 11) Has the user been given the name and telephone number of an authorized service agent?



D. Startup

Check that shipping tape(s), string and packing are removed before starting the icemaker.

- 1) Clean inside the storage bin and door.
- 2) Open the water supply line shut-of valve and plug in the icemaker.
- 3) Move the control switch to the "ICE" position. The freezing cycle will start automatically.

E. Preparing the Icemaker for Long Storage

WARNING

Drain the icemaker to prevent damage to the water supply line at subfreezing temperatures, using air or carbon dioxide. Shut of the icemaker until proper air temperature is resumed.

- 1) Close the water supply line shut-of valve, and open the drain valve.
- 2) Move the control switch to the "OFF" position.
- 3) Blow out the water supply line and the internal water circuit.

Note: This procedure is necessary to protect the icemaker from freezing up at subfreezing temperatures.

- 4) Unplug the icemaker.
- 5) Remove all ice from the storage bin, and clean the bin.
- 6) Close the drain valve.

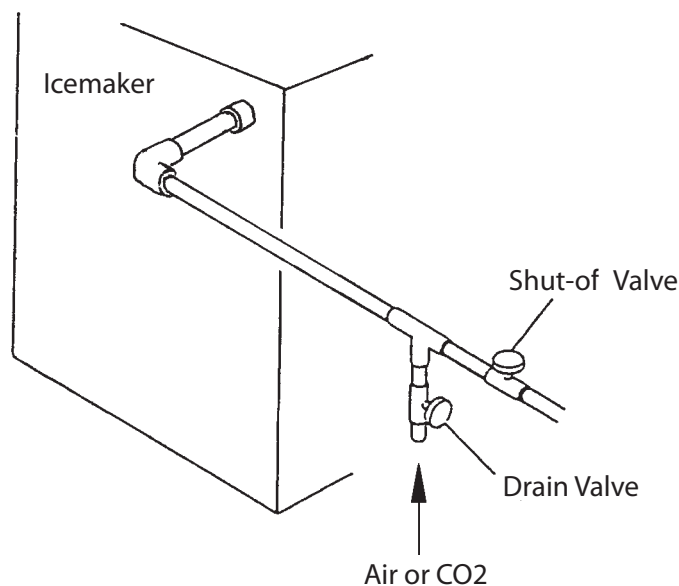

Fig. 2

III. Cleaning and Maintenance



IMPORTANT

1. Ensure all components, fasteners and thumbscrews are securely in place after any maintenance or cleaning is done to the equipment.
2. Wash your hands before removing ice. Use the scoop provided to remove ice.
3. Keep the scoop clean. Clean it by using a neutral cleaner at least once a day, and rinse thoroughly.
4. Close the bin door after removing ice to prevent entrance of dirt, dust or insects into the bin.
5. Clean the bin liner at least once a month by using a neutral cleaner. Rinse thoroughly after cleaning.
6. The storage bin is for ice use only. Do not store anything else in the bin.
7. Keep the area around the icemaker clean. Dirt, dust or insects in the icemaker could cause electrical damage to the equipment or harm to individuals.

A. Cleaning and Sanitizing Instructions

WARNING

1. Lynx recommends cleaning this unit at least once a year. More frequent cleaning, however, may be required in some existing water conditions.
2. To prevent injury to individuals and damage to the icemaker, do not use ammonia type cleaners.
3. Always wear liquid-proof gloves to prevent the cleaning and sanitizing solutions from coming into contact with skin.

1. Cleaning Solution

Dilute 5 f . oz. (148 ml) of recommended cleaner "LIME-A-WAY" (Economics Laboratory, Inc.) with 1 gallon (3.8 l) of warm water.

IMPORTANT

For safety and maximum effectiveness, use the solution immediately after dilution.



2. Cleaning Procedure

The cleaning process will remove lime deposits from the water system.

- 1) Remove all ice from the evaporator and the storage bin.

Note: To remove cubes on the evaporator, move the control switch to the "OFF" position and move it back to the "ICE" position after 3 minutes. The defrost cycle starts and the cubes will be removed from the evaporator.

- 2) Move the control switch to the "OFF" position. Close the water supply line shut-of valve.

- 3) Disconnect the suction tube by compressing both plastic tabs to unlock the joint in the direction of the black arrows and pulling the tube clear.

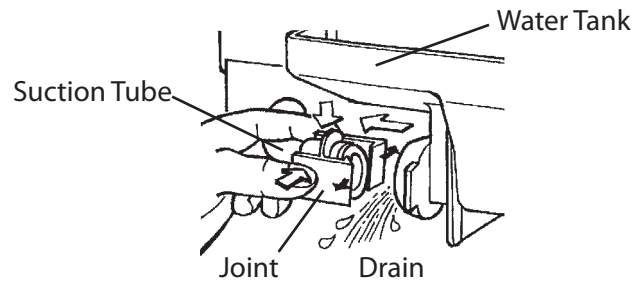

- 4) Spread out the tabs on both sides of the water tank to unlock it, then pull it out toward you. Drain the tank.

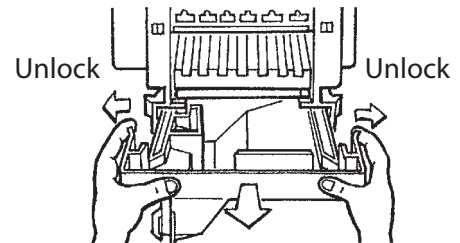

- 5) After draining, slide in the water tank along the rails at the bottom of the right and left brackets until it clicks into place.

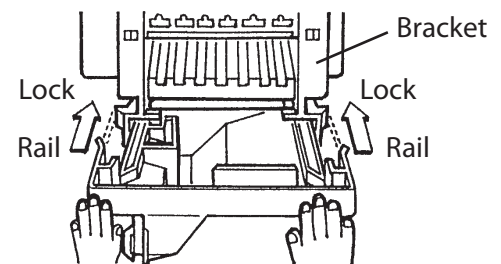

- 6) Refit the suction tube onto the water tank inlet by pushing the joint to lock it securely in the direction of the arrows. A loose fitting may cause a water leak.

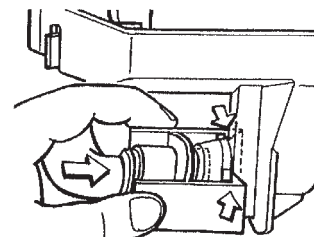

- 7) Slowly pour the cleaning solution into the water tank.

- 8) Move the control switch to the "WASH" position.

- 9) After circulating the cleaning solution for about 30 minutes, move the control switch to the "OFF" position.

- 10) Remove the water tank, drain it, and replace it as described in 3) through 6).

- 11) Open the water supply line shut-of valve.



- 12) Move the control switch to the "WASH" position to circulate clean water for about 5 minutes.
- 13) Move the control switch to the "OFF" position, then remove the water tank, drain it, and replace it as described in 3) through 6).
- 14) Repeat 12) and 13) three more times to rinse thoroughly.

3. Sanitizing Solution

Dilute 0.5 f . oz. (14.8 ml or 1 tbs) of 5.25% sodium hypochlorite solution (chlorine bleach) with 1 gallon (3.8 l) of warm water. Using a chlorine test strip or other method, confirm that you have a concentration of about 200 ppm.

IMPORTANT

For safety and maximum effectiveness, use the solution immediately after dilution.

4. Sanitizing Procedure

The sanitizing process will sanitize the icemaker.

- 1) Move the control switch to the "OFF" position.
- 2) Open the bin door and remove ice from the storage bin.
- 3) Remove the slope by bending its center carefully and releasing it from the two slope shafts. Remove the slope from the storage bin.
- 4) Thoroughly clean and sanitize the storage bin, slope, scoop and any parts normally accessible from the storage bin.
- 5) Remove each separator by lifting it to the horizontal position and pushing it hard inward. Remove all separators in the same way and clean and sanitize them.

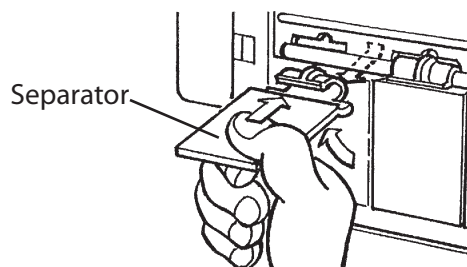

- 6) Disconnect the suction tube by compressing both plastic tabs to unlock the joint in the direction of the black arrows and pulling the tube clear to drain the tank.

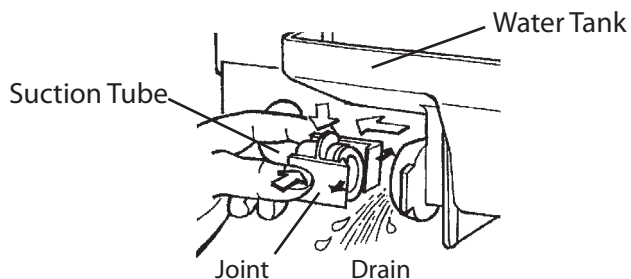



7) Spread out the tabs on both sides to unlock the water tank, and pull it out toward you. Soak the water tank in the sanitizing solution for 10 minutes.

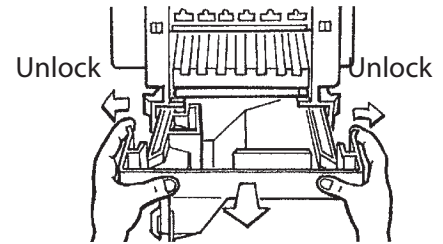

8) Lift off the ice chute from the front frame pipe and then from the rear frame pipe. Soak the ice chute in the sanitizing solution for 10 minutes.

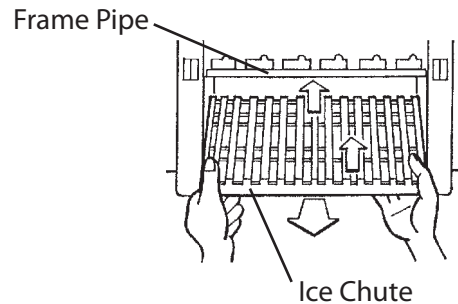

9) Pull the discharge tube from the spray assembly. Remove the assembly by pulling it toward you.

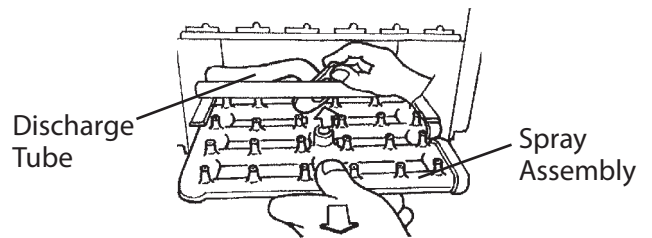

10) Remove the two caps. Soak the caps and the spray assembly in the sanitizing solution for 10 minutes. If the nozzles are clogged, clean them with a wire or a suitable brush.

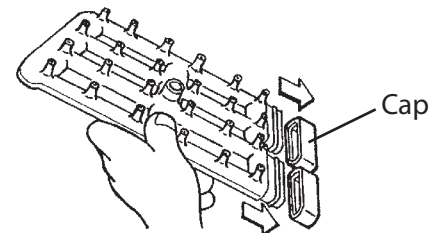

11) Refit the two caps in their correct positions. Make sure the reducing pipe is in place in the center.

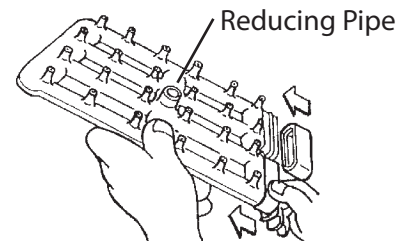

12) Slide in the spray assembly along the rails on the right and left brackets. Refit the discharge tube securely on the spray assembly. A loose fitting may cause a water leak.

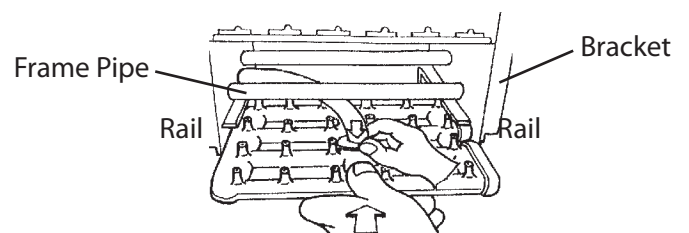



13) Position and lock the ice chute onto the front and rear frame pipes by pushing the chute down until it clicks onto both pipes.

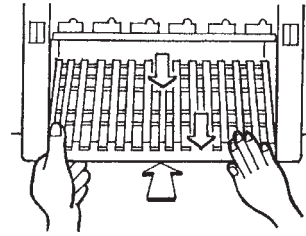

14) Slide in the water tank along the rails at the bottom of the right and left brackets until it clicks into place.

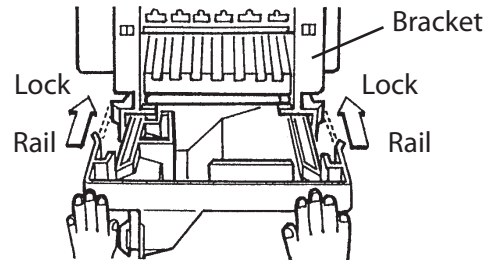

15) Refit the suction tube onto the water tank inlet by pushing the joint to lock it securely in the direction of the arrows. A loose fitting may cause a water leak.

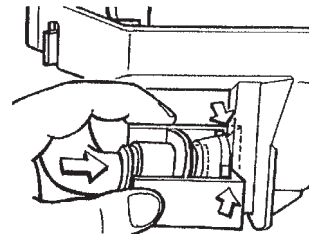

16) Hook each separator onto the rail, and pull it hard toward you until it locks in place with a click. Refit all the separators in the same way.

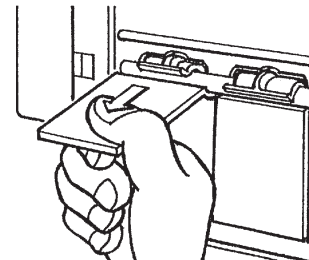

17) Refit the slope in its correct position.

18) Close the water supply line shut-of valve.

19) Discard the sanitizing solution.

20) Mix a new batch of the sanitizing solution and slowly pour it into the water tank.

21) Move the control switch to the "WASH" position.

22) After circulating the sanitizing solution for about 15 minutes, move the control switch to the "OFF" position.

23) Disconnect the suction tube by compressing both plastic tabs to unlock the joint in the direction of the black arrows and pulling the tube clear.

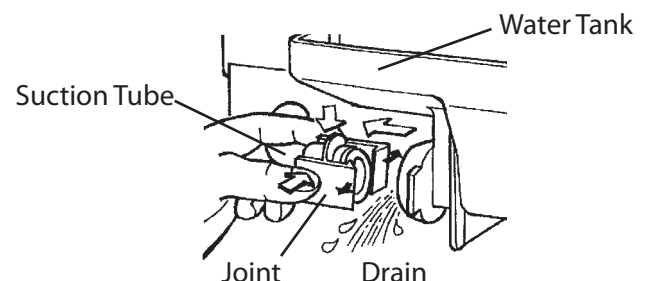

Important Safety Instructions



24) Spread out the tabs on both sides of the water tank to unlock it, then pull it out toward you. Drain the tank.

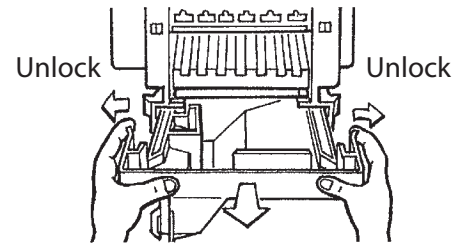

25) After draining, slide in the water tank along the rails at the bottom of the right and left brackets until it clicks into place.

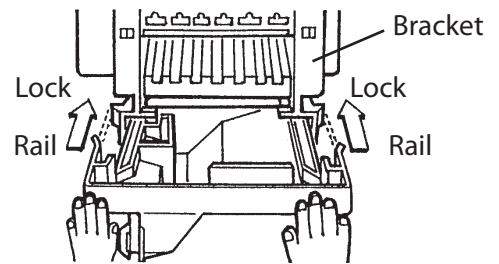

26) Refit the suction tube onto the water tank inlet by pushing the joint to lock it securely in the direction of the arrows. A loose fitting may cause a water leak.

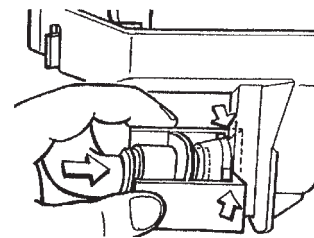

27) Repeat 20) through 26) one time.

28) Open the water supply line shut-off valve.

29) Move the control switch to the "WASH" position to circulate clean water for about 5 minutes.

30) Move the control switch to the "OFF" position, then remove the water tank, drain it, and replace it as described in 23) through 26).

31) Repeat 29) and 30) two more times to rinse thoroughly.

32) Move the control switch to the "ICE" position, and start the automatic icemaking process.

B. Maintenance

IMPORTANT

This icemaker must be maintained individually, referring to the instruction manual and labels provided with the icemaker.

1) Exterior

To keep the exterior clean, wipe occasionally with a clean and soft cloth. Use a damp cloth containing a neutral cleaner to wipe off all oil or dirt build-up.

2) Condenser

Check the condenser once a year, and clean the coil if required by using a brush or vacuum cleaner. More frequent cleaning may be required depending on the location of the icemaker.

